

LOW NOISE 150mA LDO Regulator

NO.EA-107-130410

OUTLINE

The R1115Z Series are CMOS-based voltage regulator ICs with extremely low supply current, low ON-resistance, and high ripple rejection. Each of these ICs consists of a voltage reference unit, an error amplifier, resistor-net for voltage setting, a current limit circuit, and a chip-enable circuit.

These ICs perform with low dropout voltage and a chip-enable function. The line transient response and load transient response of the R1115Z Series are excellent, thus these ICs are very suitable for the power supply for hand-held communication equipment.

The output voltage of these ICs is fixed with high accuracy. Since the package for these ICs is WLCSP-4-P4, therefore high density mounting of the ICs on boards is possible.

FEATURES

- Supply Current Typ. 75 μ A
- Standby Current Typ. 0.1 μ A
- Output Voltage Range..... 1.5V to 4.0V (0.1V steps)
(For other voltages, please refer to MARK INFORMATION.)
- Dropout Voltage Typ. 0.22V ($I_{OUT}=150\text{mA}$, $V_{OUT}=3.0\text{V}$)
- Ripple Rejection Typ. 70dB ($f=1\text{kHz}$)
Typ. 60dB ($f=10\text{kHz}$)
- Temperature-Drift Coefficient of Output Voltage Typ. $\pm 100\text{ppm}/^\circ\text{C}$
- Line Regulation Typ. 0.02%/V
- Output Voltage Accuracy $\pm 2.0\%$
- Package WLCSP-4-P4
- Built-in Fold Back Protection Circuit Typ. 40mA (Current at short mode)
- Ceramic capacitors are recommended to be used with this IC ... $C_{IN}=C_{OUT}=1\mu\text{F}$ ($V_{OUT}<2.5\text{V}$)
 $C_{IN}=1\mu\text{F}$, $C_{OUT}=0.47\mu\text{F}$ ($V_{OUT} \geq 2.5\text{V}$)

APPLICATIONS

- Power source for portable communication equipment.
- Power source for electrical appliances such as cameras, VCRs and camcorders.
- Power source for battery-powered equipment.

BLOCK DIAGRAMS

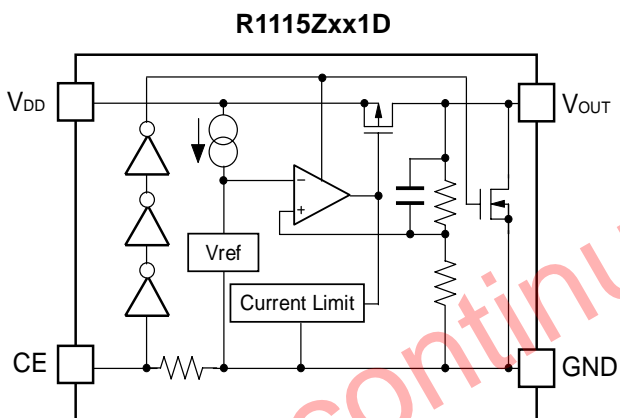
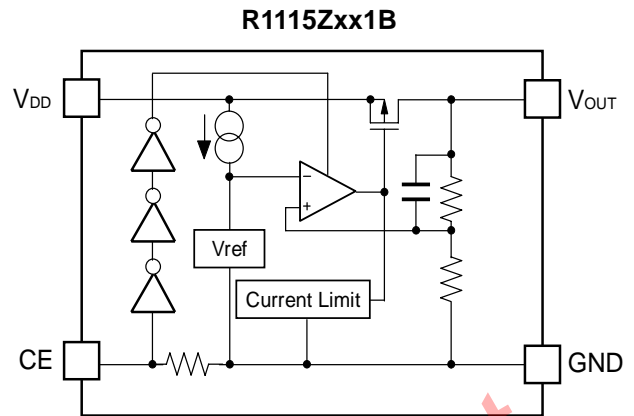
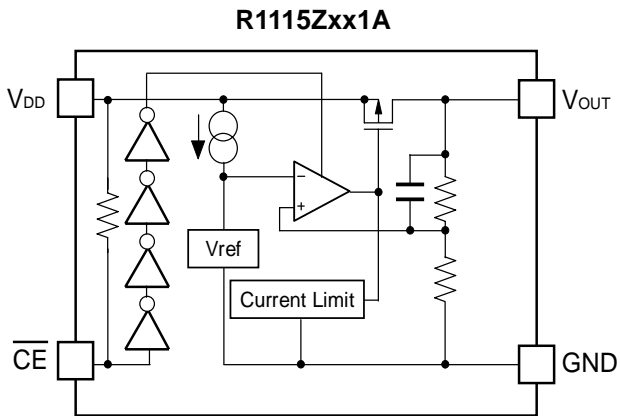

Discontinued Product

SELECTION GUIDE

The output voltage, auto discharge function, etc. for the ICs can be selected at the user's request.

Product Name	Package	Quantity per Reel	Pb Free	Halogen Free
R1115Zxx1*-TR-F	WLCSP-4-P4	3,000 pcs	Yes	Yes
xx: The output voltage can be designated in the range from 1.5V(15) to 4.0V(40) in 0.1V steps. (For other voltages, please refer to MARK INFORMATIONS.)				
* : CE pin polarity and auto discharge function at off state are options as follows. (A) "L" active, without auto discharge function at off state (B) "H" active, without auto discharge function at off state (D) "H" active, with auto discharge function at off state				

PIN CONFIGURATION

● WLCSP-4-P4

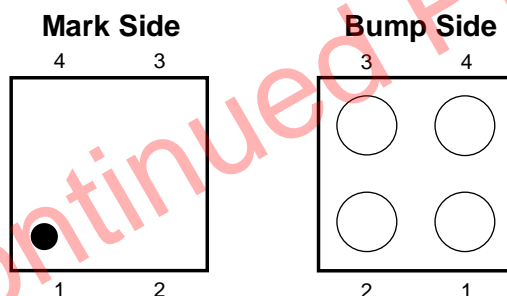

PIN DESCRIPTION

● R1115Z

Pin No.	Symbol	Description
1	V_{DD}	Input Pin
2	\overline{CE} or CE	Chip Enable Pin
3	GND	Ground Pin
4	V_{OUT}	Output pin

ABSOLUTE MAXIMUM RATING

Symbol	Item	Rating	Unit
V_{IN}	Input Voltage	6.5	V
V_{CE}	Input Voltage (\overline{CE} or CE Pin)	6.5	V
V_{OUT}	Output Voltage	-0.3 to $V_{IN}+0.3$	V
I_{OUT}	Output Current	200	mA
P_D	Power Dissipation*	600	mW
T_{opt}	Operating Temperature Range	-40 to 85	°C
T_{stg}	Storage Temperature Range	-55 to 125	°C

*) For Power Dissipation, please refer to PACKAGE INFORMATION.

ABSOLUTE MAXIMUM RATINGS

Electronic and mechanical stress momentarily exceeded absolute maximum ratings may cause the permanent damages and may degrade the life time and safety for both device and system using the device in the field.

The functional operation at or over these absolute maximum ratings is not assured.

RECOMMENDED OPERATING CONDITIONS (ELECTRICAL CHARACTERISTICS)

All of electronic equipment should be designed that the mounted semiconductor devices operate within the recommended operating conditions. The semiconductor devices cannot operate normally over the recommended operating conditions, even if when they are used over such conditions by momentary electronic noise or surge. And the semiconductor devices may receive serious damage when they continue to operate over the recommended operating conditions.

ELECTRICAL CHARACTERISTICS

• R1115Zxx1A

T_{opt}=25°C

Symbol	Item	Conditions	Min.	Typ.	Max.	Unit	
V _{OUT}	Output Voltage	V _{IN} =Set V _{OUT} +1V 1mA ≤ I _{OUT} ≤ 30mA	×0.98		×1.02	V	
I _{OUT}	Output Current	V _{IN} -V _{OUT} =1.0V	150			mA	
ΔV _{OUT} /ΔI _{OUT}	Load Regulation	V _{IN} =Set V _{OUT} +1V 1mA ≤ I _{OUT} ≤ 150mA		22	40	mV	
V _{DIF}	Dropout Voltage	I _{OUT} =150mA	V _{OUT} = 1.5V		0.38	0.70	V
			V _{OUT} = 1.6V		0.36	0.65	
			V _{OUT} = 1.7V		0.34	0.60	
			1.8V ≤ V _{OUT} ≤ 2.0V		0.32	0.55	
			2.1V ≤ V _{OUT} ≤ 2.7V		0.28	0.50	
			2.8V ≤ V _{OUT} ≤ 4.0V		0.22	0.35	
I _{SS}	Supply Current	V _{IN} =Set V _{OUT} +1V, I _{OUT} =0mA		75	95	μA	
I _{standby}	Standby Current	V _{IN} =Set V _{OUT} +1V V _{CE} =V _{DD}		0.1	1.0	μA	
ΔV _{OUT} /ΔV _{IN}	Line Regulation	I _{OUT} =30mA V _{OUT} > 1.6V, Set V _{OUT} +0.5V ≤ V _{IN} ≤ 6.0V (V _{OUT} ≤ 1.6V, 2.2V ≤ V _{IN} ≤ 6.0V)		0.02	0.10	%/V	
RR	Ripple Rejection	Ripple 0.5Vp-p I _{OUT} =30mA V _{OUT} >1.7V, V _{IN} -V _{OUT} =1.0V (V _{OUT} ≤ 1.7V, V _{IN} -V _{OUT} =1.2V)	f=1kHz		70	dB	
			f=10kHz		60		
V _{IN}	Input Voltage		2.0		6.0	V	
ΔV _{OUT} /ΔT _{opt}	Output Voltage Temperature Coefficient	I _{OUT} =30mA -40°C ≤ T _{opt} ≤ 85°C		±100		ppm/°C	
I _{SC}	Short Current Limit	V _{OUT} =0V		40		mA	
R _{PU}	\overline{CE} Pull-up Resistance		0.7	2.0	8.0	MΩ	
V _{CEH}	\overline{CE} Input Voltage "H"		1.5		6.0	V	
V _{CEL}	\overline{CE} Input Voltage "L"		0		0.3	V	
en	Output Noise	BW =10Hz to 100kHz		30		μVrms	

R1115Z

• R1115Zxx1B/D

T_{opt}=25°C

Symbol	Item	Conditions	Min.	Typ.	Max.	Unit	
V _{OUT}	Output Voltage	V _{IN} =Set V _{OUT} +1V 1mA ≤ I _{OUT} ≤ 30mA	×0.98		×1.02	V	
I _{OUT}	Output Current	V _{IN} -V _{OUT} =1.0V	150			mA	
ΔV _{OUT} /ΔI _{OUT}	Load Regulation	V _{IN} =Set V _{OUT} +1V 1mA ≤ I _{OUT} ≤ 150mA		22	40	mV	
V _{DIF}	Dropout Voltage	I _{OUT} =150mA	V _{OUT} = 1.5V		0.38	0.70	V
			V _{OUT} = 1.6V		0.36	0.65	
			V _{OUT} = 1.7V		0.34	0.60	
			1.8V ≤ V _{OUT} ≤ 2.0V		0.32	0.55	
			2.1V ≤ V _{OUT} ≤ 2.7V		0.28	0.50	
			2.8V ≤ V _{OUT} ≤ 4.0V		0.22	0.35	
I _{SS}	Supply Current	V _{IN} =Set V _{OUT} +1V, I _{OUT} =0mA		75	95	μA	
I _{standby}	Standby Current	V _{IN} =Set V _{OUT} +1V, V _{CE} =GND		0.1	1.0	μA	
ΔV _{OUT} /ΔV _{IN}	Line Regulation	I _{OUT} =30mA V _{OUT} >1.6V, Set V _{OUT} +0.5V ≤ V _{IN} ≤ 6.0V (V _{OUT} ≤ 1.6V, 2.2V ≤ V _{IN} ≤ 6.0V)		0.02	0.10	%/V	
RR	Ripple Rejection	Ripple 0.5Vp-p I _{OUT} =30mA V _{OUT} >1.7V, V _{IN} -V _{OUT} =1.0V (V _{OUT} ≤ 1.7V, V _{IN} -V _{OUT} =1.2V)	f=1kHz		70	dB	
			f=10kHz		60		
V _{IN}	Input Voltage		2.0		6.0	V	
ΔV _{OUT} /ΔT _{opt}	Output Voltage Temperature Coefficient	I _{OUT} =30mA -40°C ≤ T _{opt} ≤ 85°C		±100		ppm/°C	
I _{SC}	Short Current Limit	V _{OUT} =0V		40		mA	
R _{PD}	CE Pull-down Resistance		0.7	2.0	8.0	MΩ	
V _{CEH}	CE Input Voltage "H"		1.5		6.0	V	
V _{CEL}	CE Input Voltage "L"		0		0.3	V	
e _n	Output Noise	BW=10Hz to 100kHz		30		μVrms	
R _{LOW}	On Resistance of Nch for auto discharge (Only for D version)	V _{CE} =0V		60		Ω	

TYPICAL APPLICATIONS

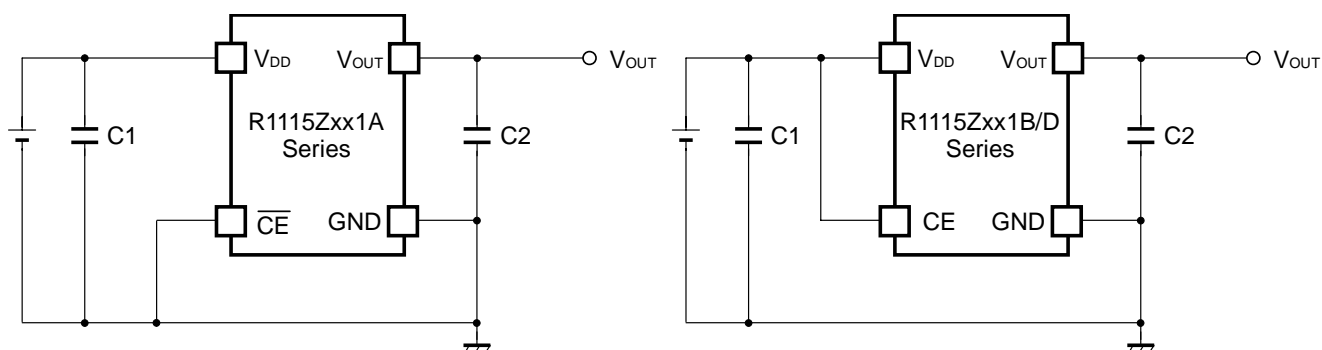

(External Components)

Output Capacitor; Ceramic $0.47\mu\text{F}$ (Set Output Voltage in the range from 2.5 to 4.0V)

Ceramic $1.0\mu\text{F}$ (Set Output Voltage in the range from 1.5 to 2.4V)

Input Capacitor; Ceramic $1.0\mu\text{F}$

TECHNICAL NOTES

When using these ICs, consider the following points:

Phase Compensation

In these ICs, phase compensation is made for securing stable operation even if the load current is varied. For this purpose, use a capacitor C2. Recommendation value is as follows:

If you use a tantalum type capacitor and ESR value of the capacitor is large, output might be unstable. Evaluate your circuit with considering frequency characteristics.

Output Voltage	C2 recommendation value
$V_{\text{OUT}} \leq 2.4\text{V}$	$1.0\mu\text{F}$ or more
$2.5 \leq V_{\text{OUT}}$	$0.47\mu\text{F}$ or more

PCB Layout

Make V_{DD} and GND lines sufficient. If their impedance is high, noise pickup or unstable operation may result. Connect a capacitor C1 with a capacitance value as much as $1\mu\text{F}$ or more between V_{DD} and GND pin, and as close as possible to the pins.

Set external components, especially the output capacitor C2, as close as possible to the ICs, and make wiring as short as possible.

TEST CIRCUITS

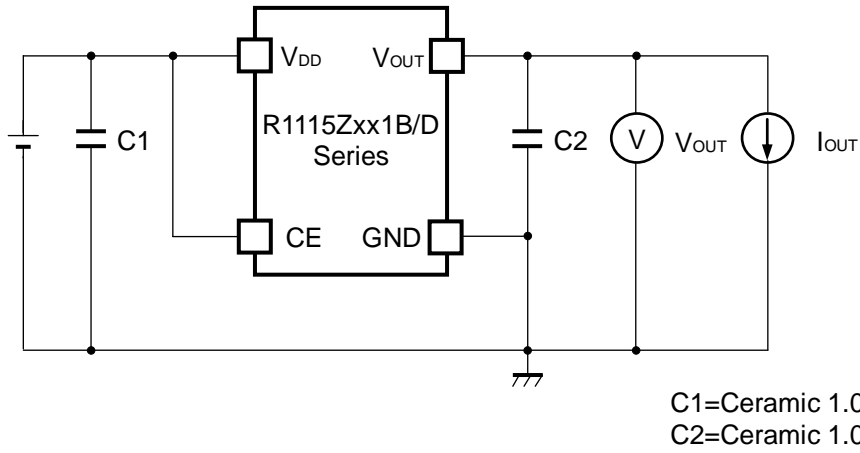

Fig.1 Standard test Circuit

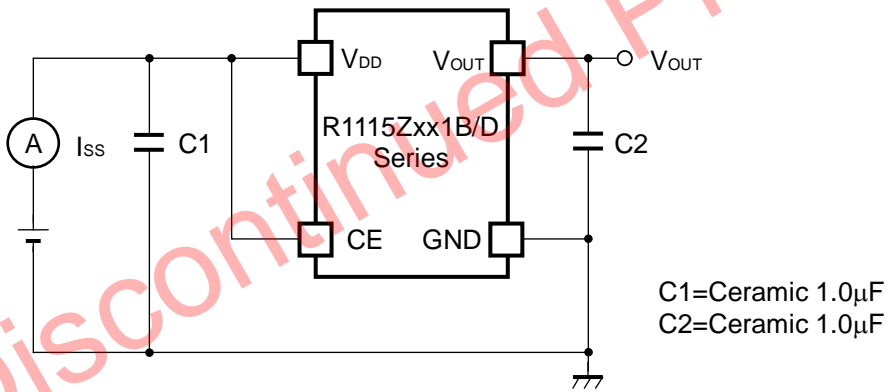

Fig.2 Supply Current Test Circuit

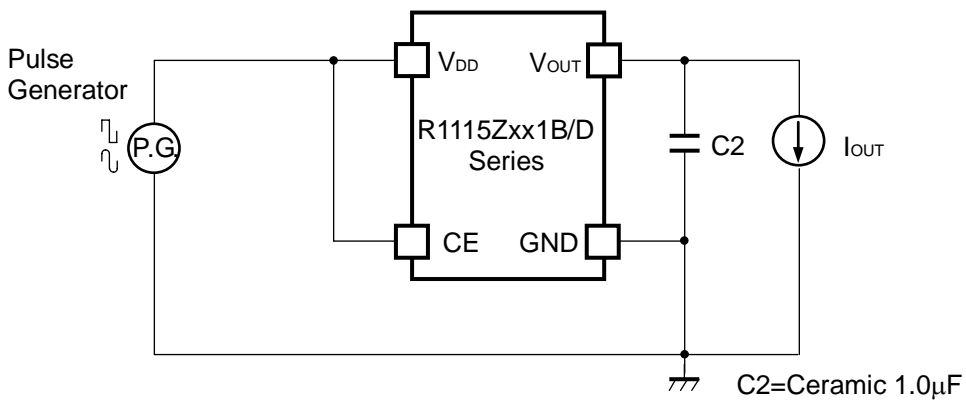

Fig.3 Ripple Rejection, Line Transient Response Test Circuit

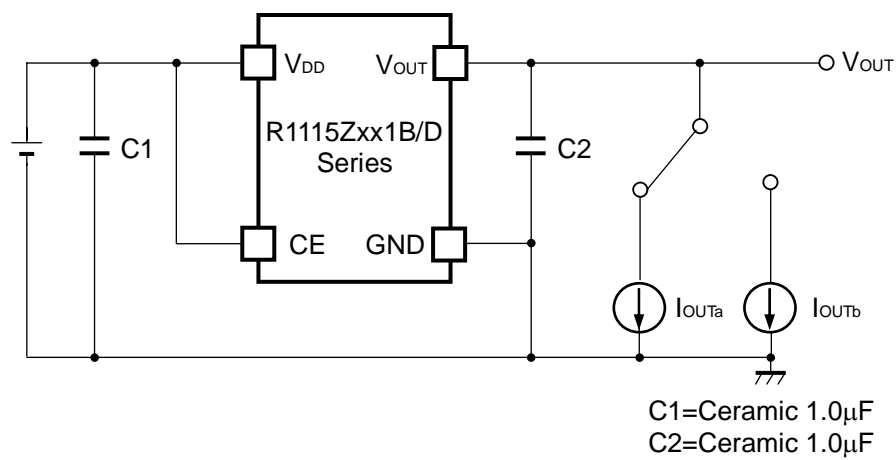
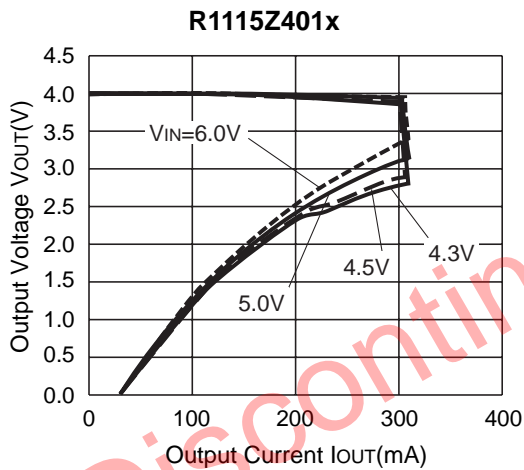
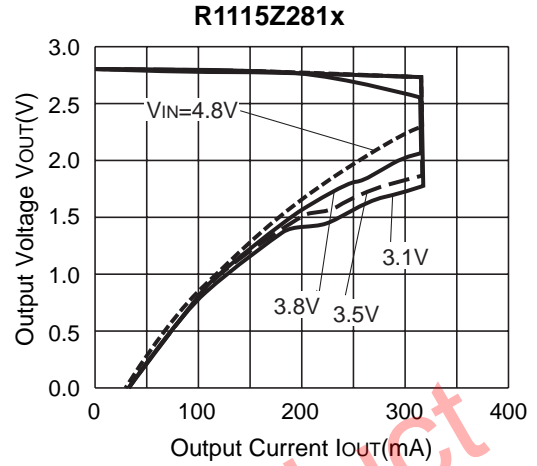
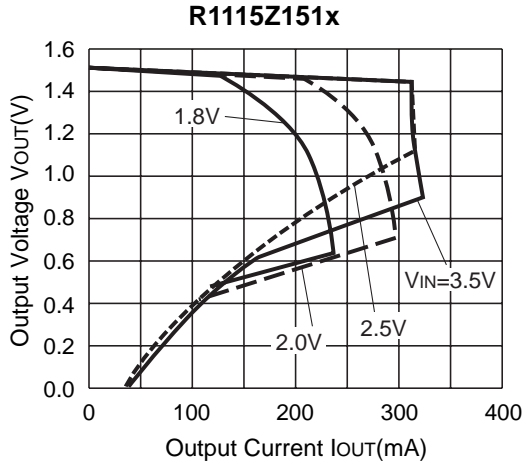

Fig.4 Load Transient Response Test Circuit

Discontinued Product

TYPICAL CHARACTERISTICS

1) Output Voltage vs. Output Current ($T_{opt}=25^{\circ}\text{C}$)



2) Output Voltage vs. Input Voltage ($T_{opt}=25^{\circ}\text{C}$)

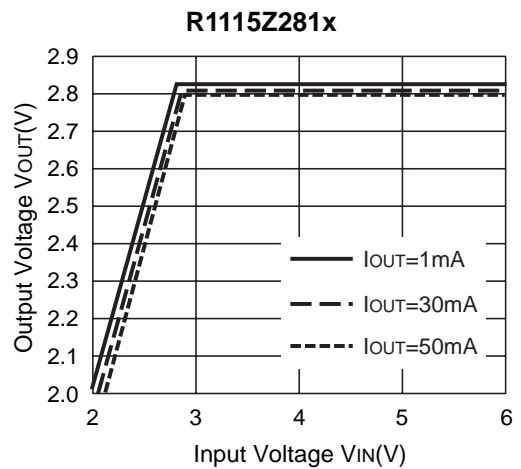
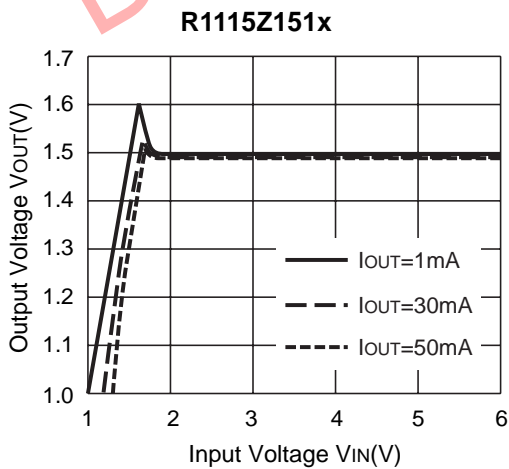

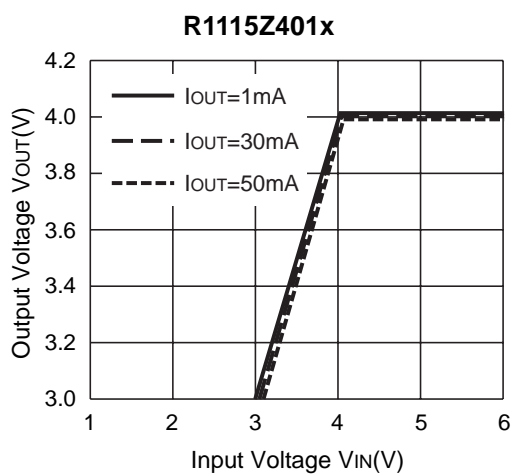

3) Supply Current vs. Input Voltage ($T_{opt}=25^{\circ}C$)

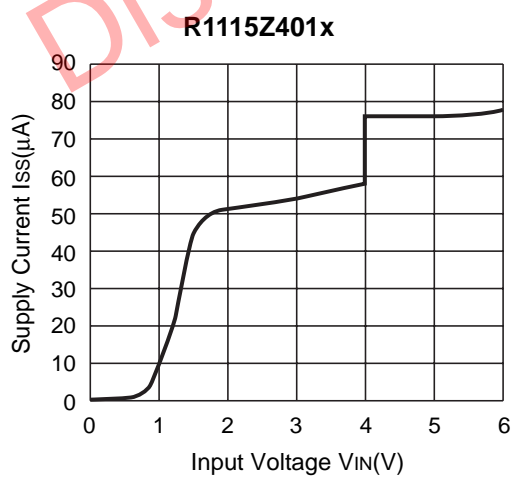
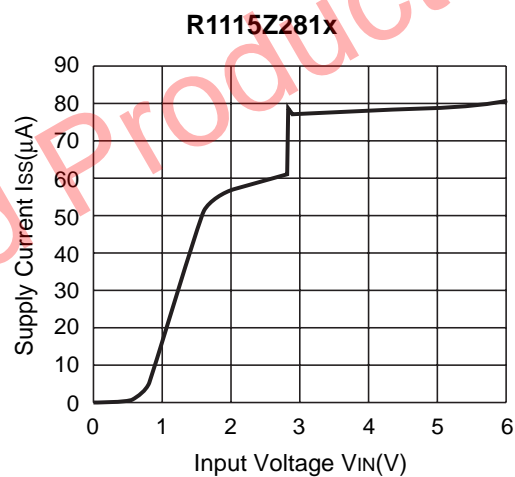
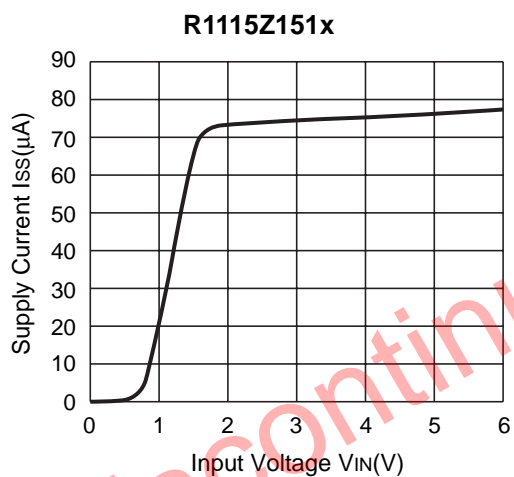

4) Output Voltage vs. Temperature

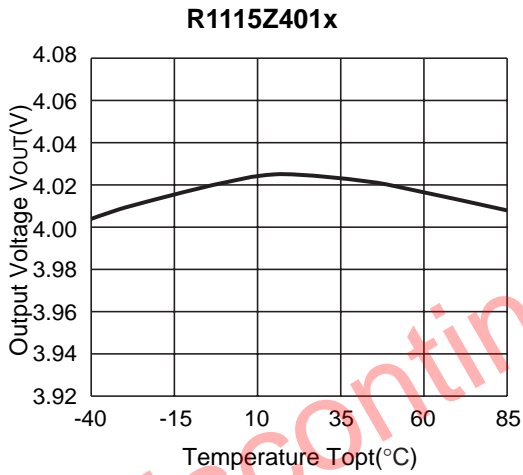
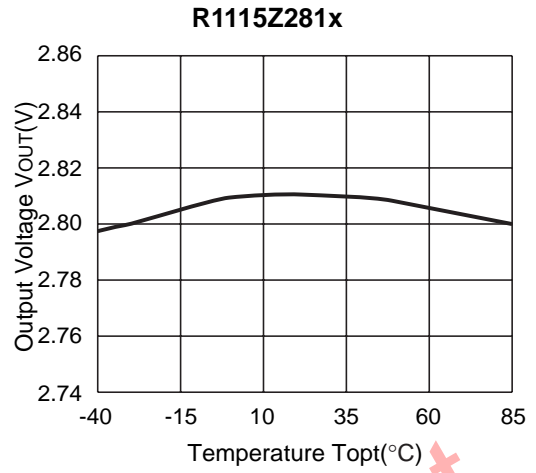
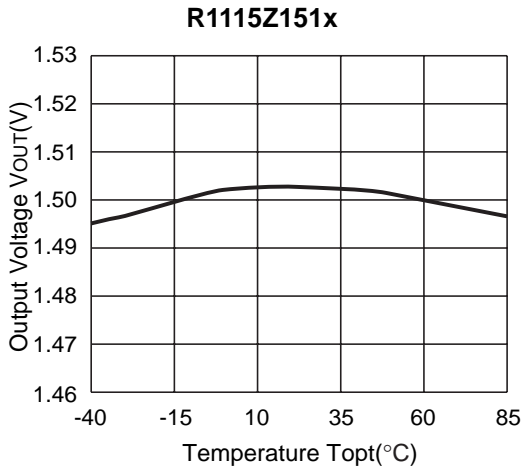

5) Supply Current vs. Temperature

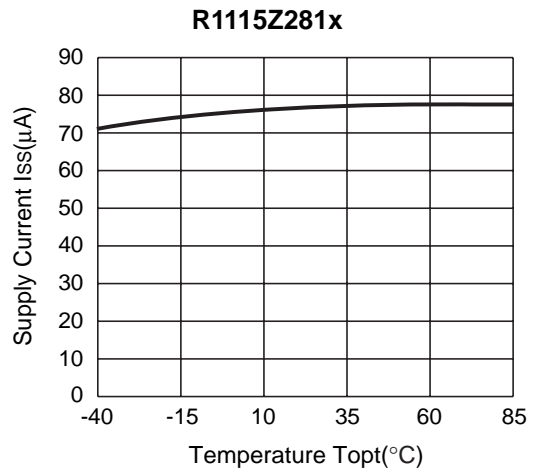
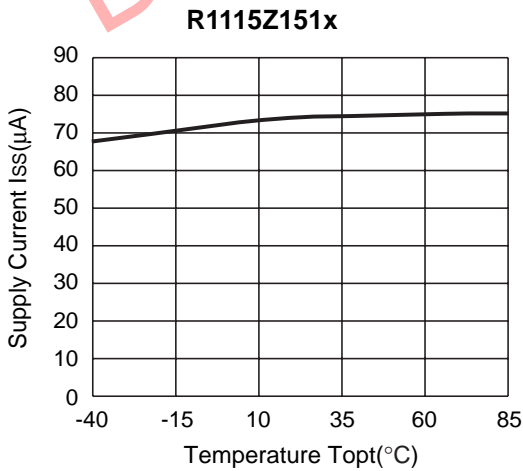

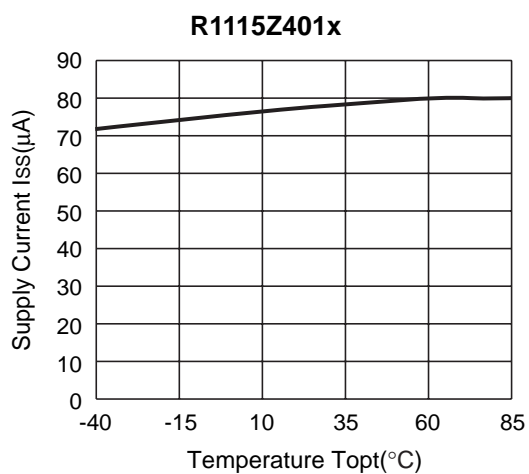

6) Dropout Voltage vs. Output Current

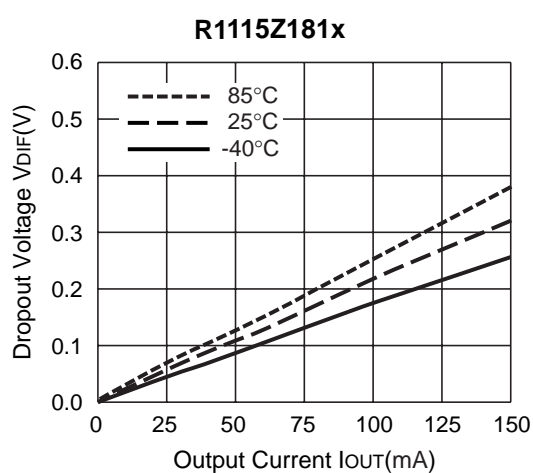
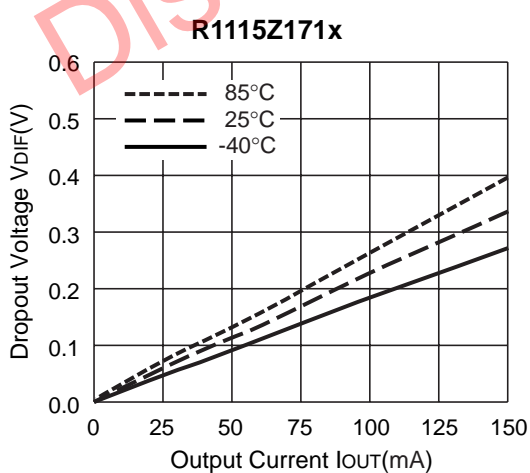
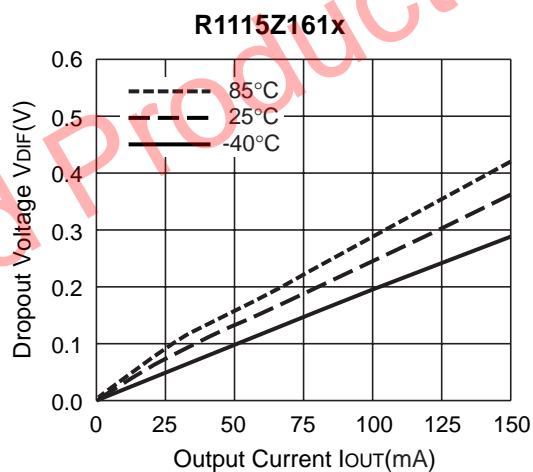
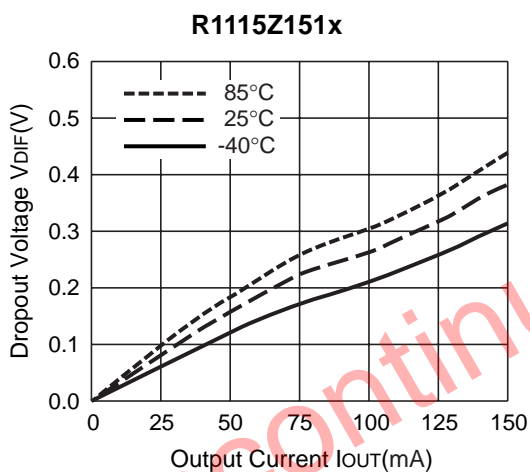

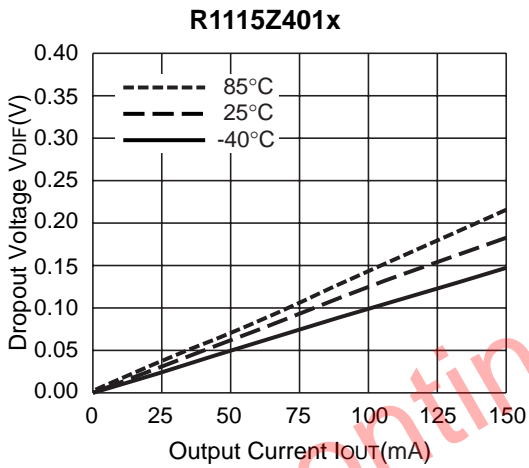
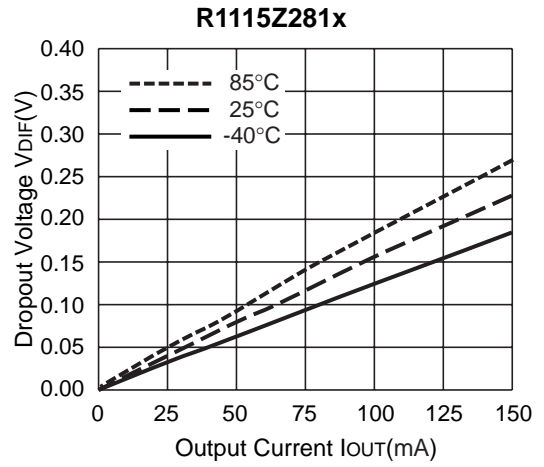
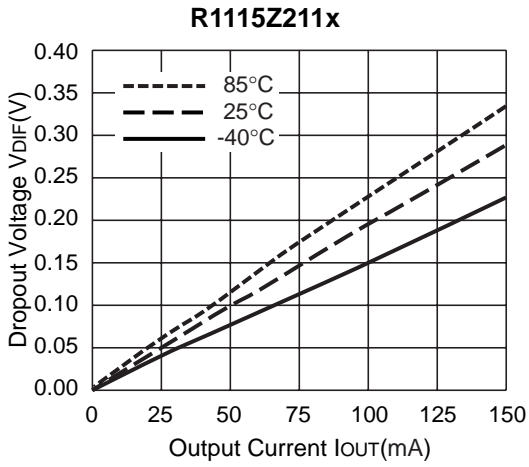

7) Dropout Voltage vs. Set Output Voltage ($T_{opt}=25^{\circ}\text{C}$)

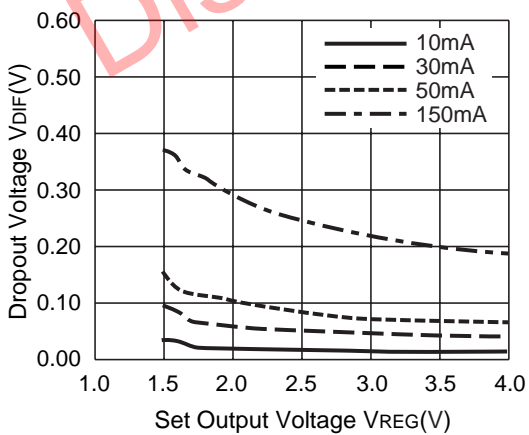

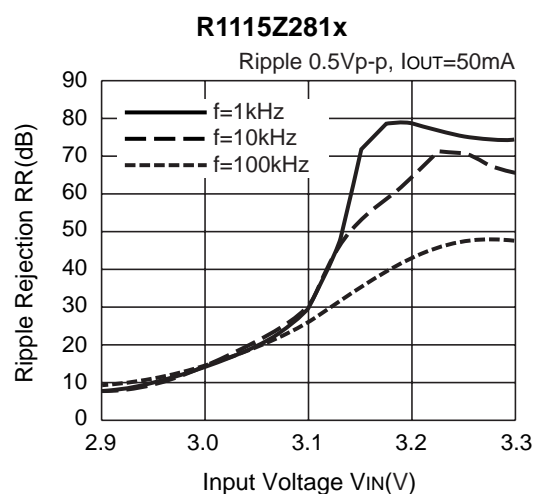
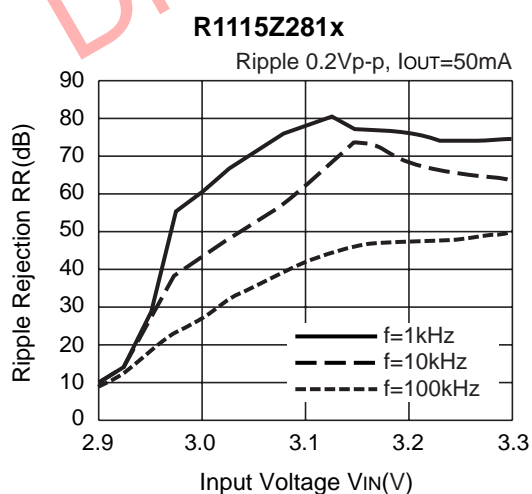
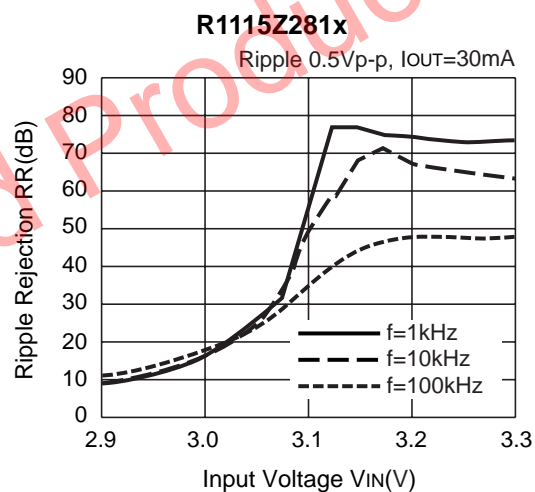
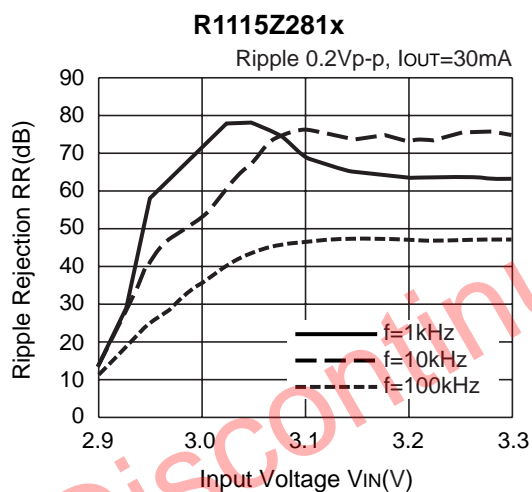
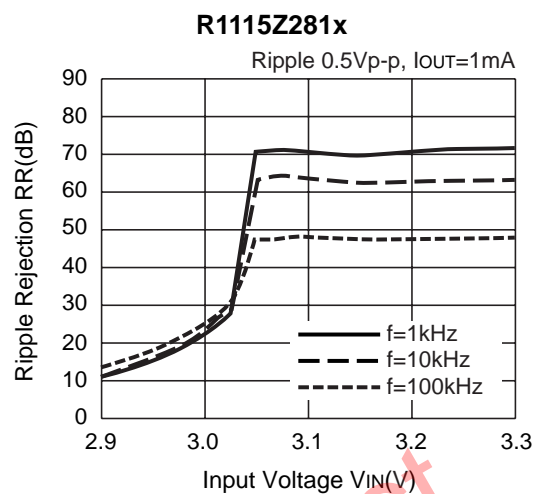
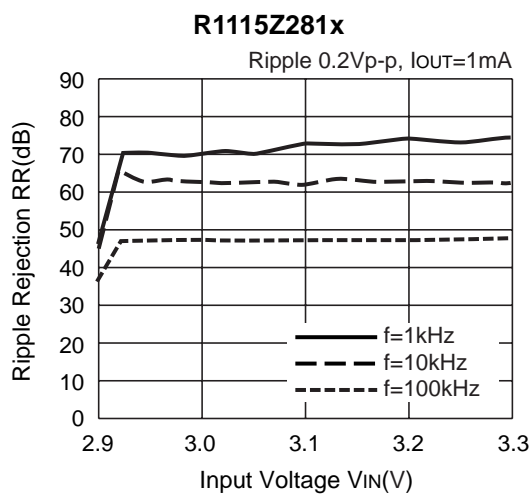
8) Ripple Rejection vs. Input Bias Voltage ($T_{opt}=25^{\circ}\text{C}$, $C_{IN}=\text{none}$, $C_{OUT}=\text{ceramic } 0.47\mu\text{F}$)

9) Ripple Rejection vs. Frequency (C_{IN} =none)

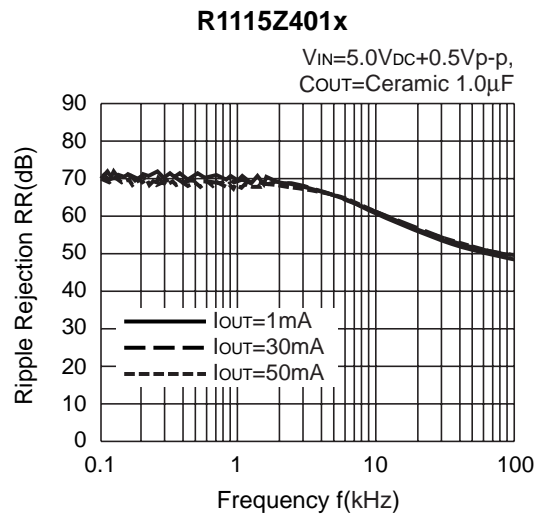
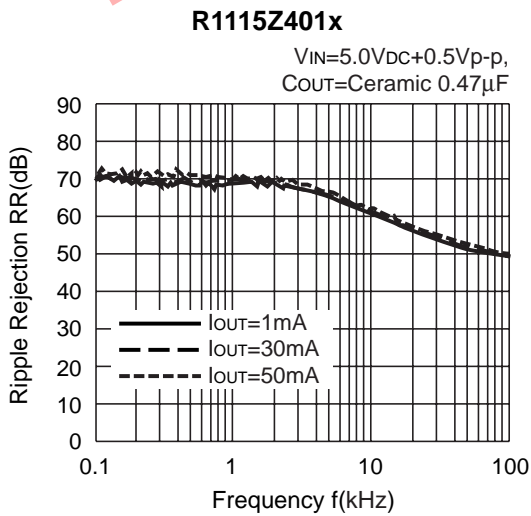
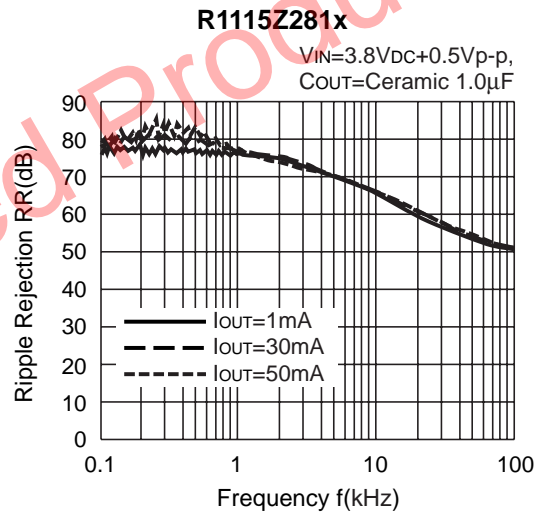
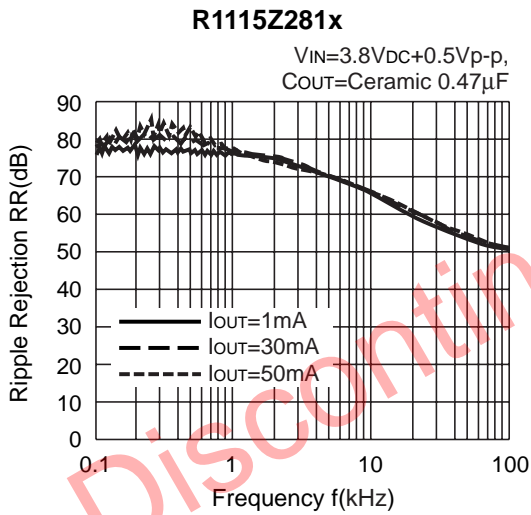
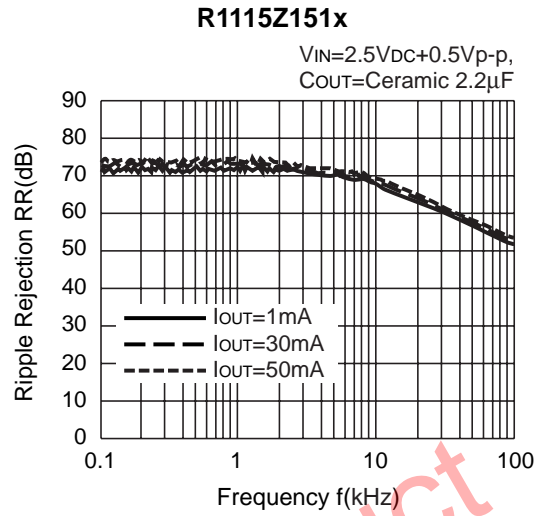
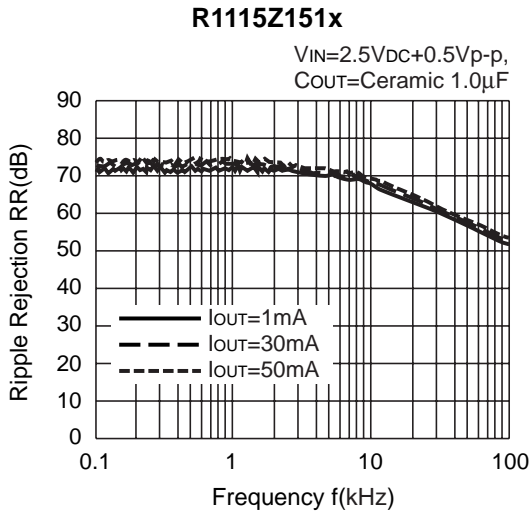

10) Input Transient Response ($I_{OUT}=30\text{mA}$, $C_{IN}=\text{none}$, $t_r=t_f=5\mu\text{s}$, $C_{OUT}=\text{Ceramic } 0.47\mu\text{F}$)

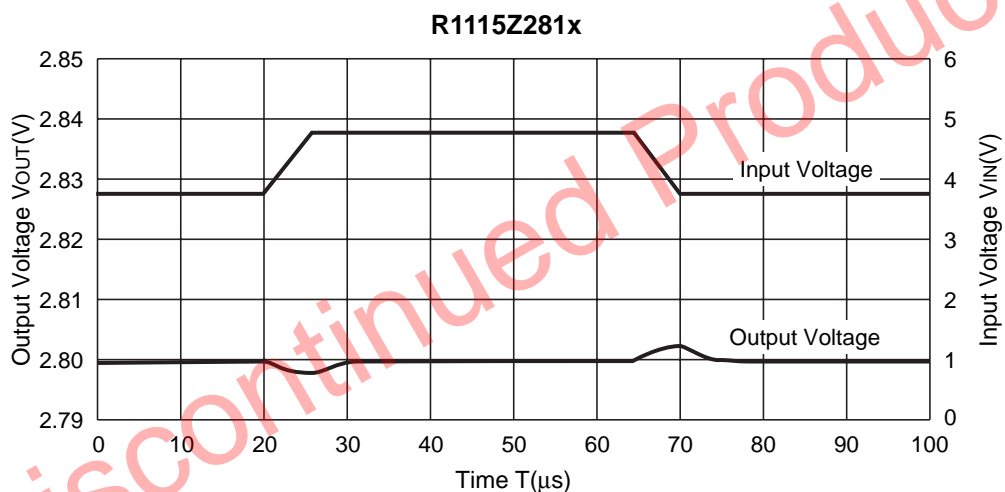
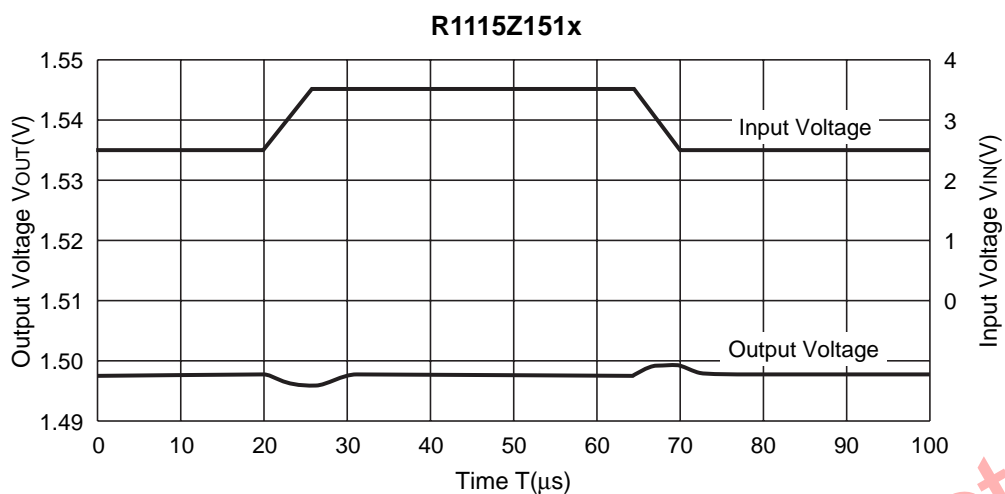

11) Load Transient Response ($t_r=t_f=0.5\mu\text{s}$, $C_{IN}=\text{Ceramic } 1.0\mu\text{F}$)

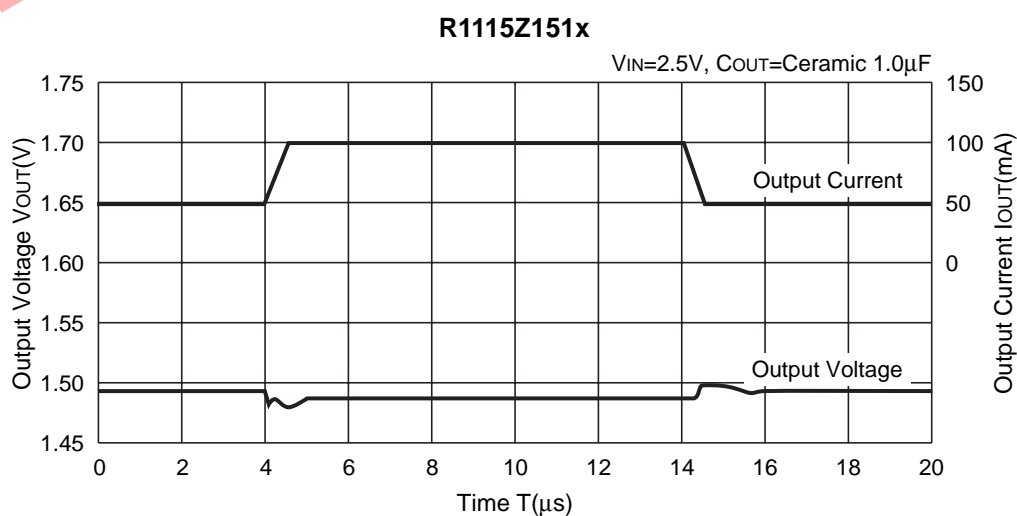

R1115Z151x

V_{IN}=2.5V, C_{OUT}=Ceramic 2.2μF

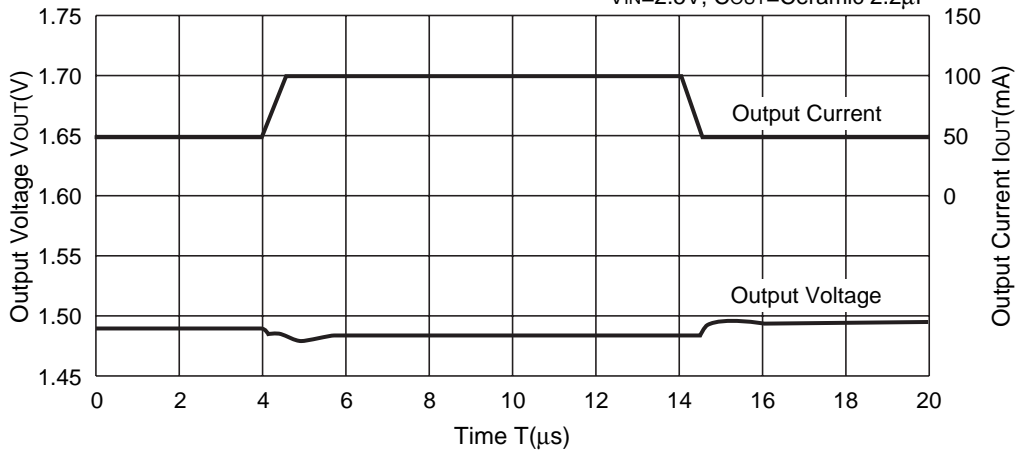

R1115Z281x

V_{IN}=3.8V, C_{OUT}=Ceramic 0.47μF

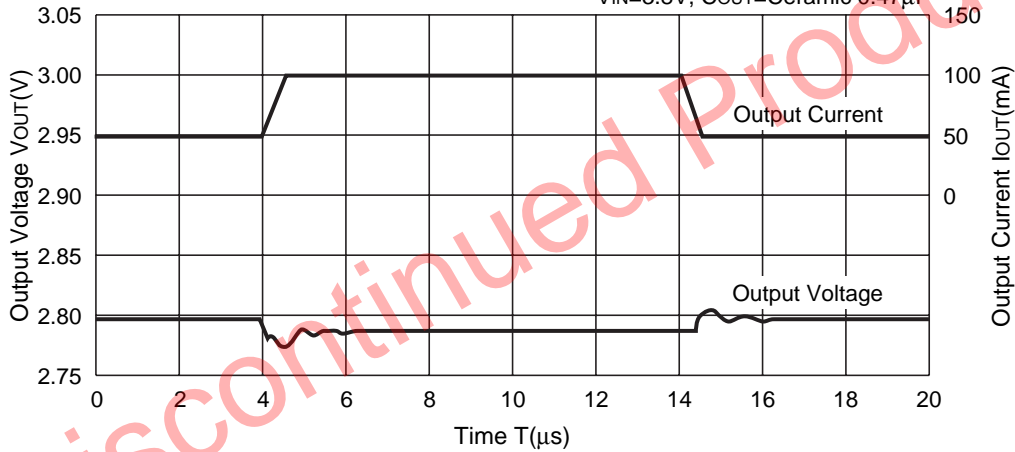

R1115Z281x

V_{IN}=3.8V, C_{OUT}=Ceramic 1.0μF

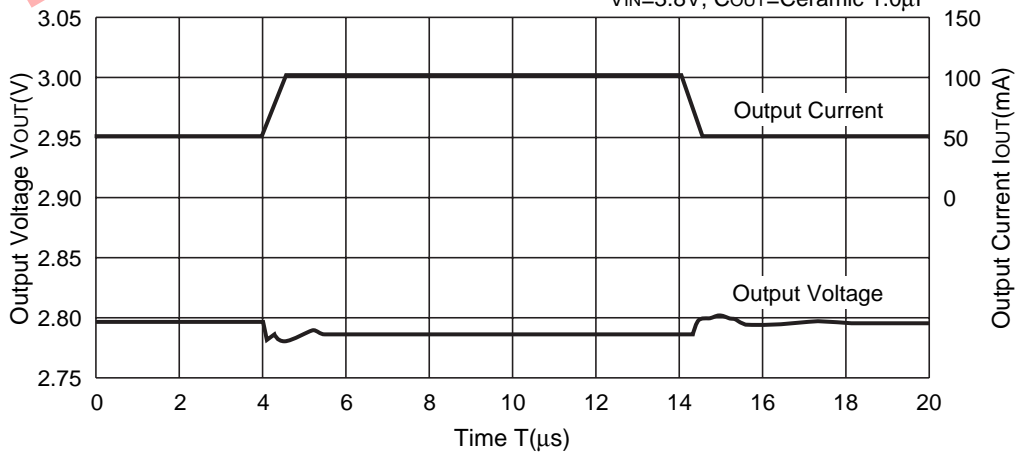

Discontinued Product

R1115Z281x

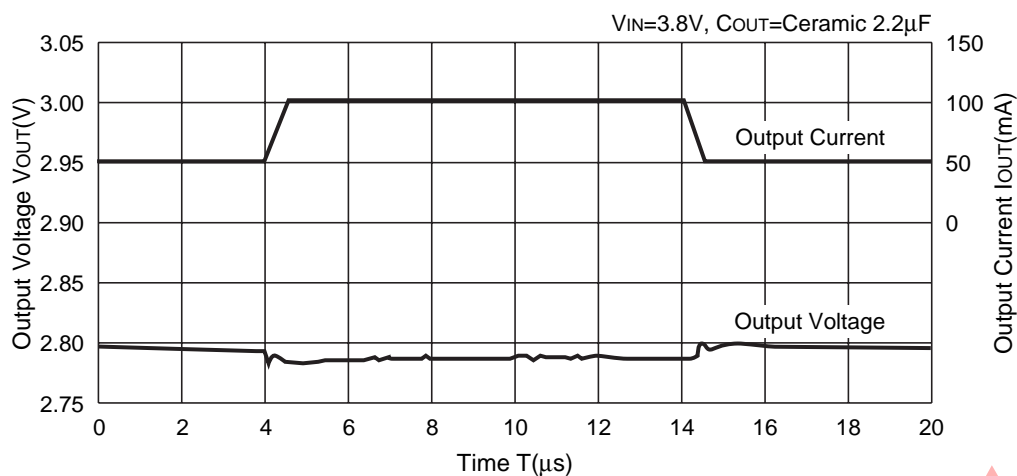

12) Turn-on/off speed with CE pin (D version)

R1115Z151D ($V_{IN}=2.5V$, $C_{IN}=\text{Ceramic } 1.0\mu F$, $C_{OUT}=\text{Ceramic } 1.0\mu F$)

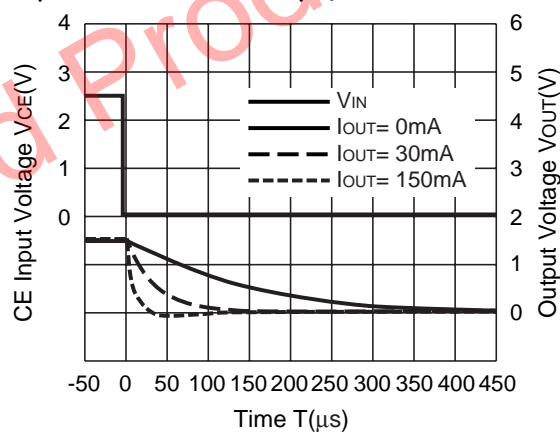
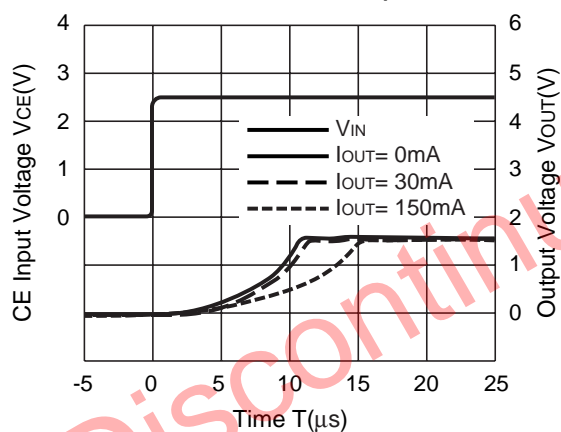

R1115Z281D ($V_{IN}=3.8V$, $C_{IN}=\text{Ceramic } 0.47\mu F$, $C_{OUT}=\text{Ceramic } 0.47\mu F$)

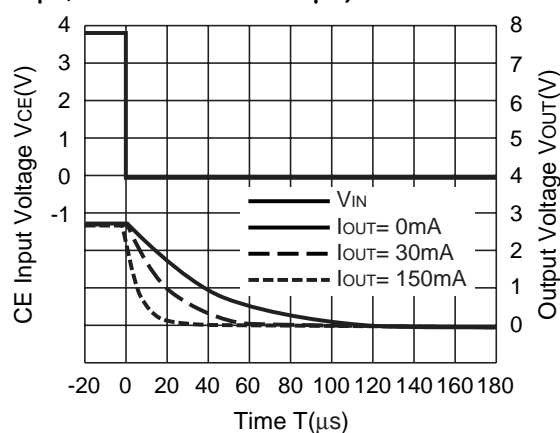
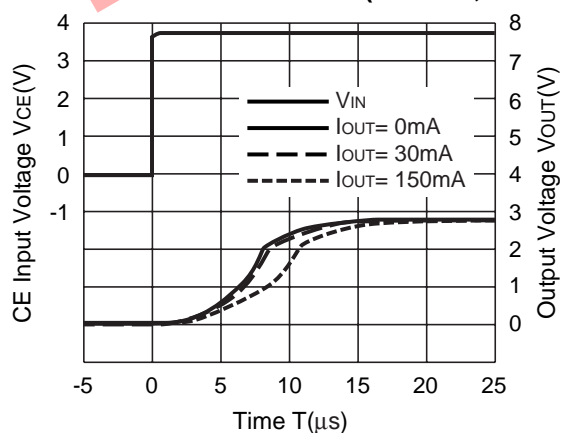

R1115Z401D ($V_{IN}=5.0V$, $C_{IN}=\text{Ceramic } 0.47\mu F$, $C_{OUT}=\text{Ceramic } 0.47\mu F$)

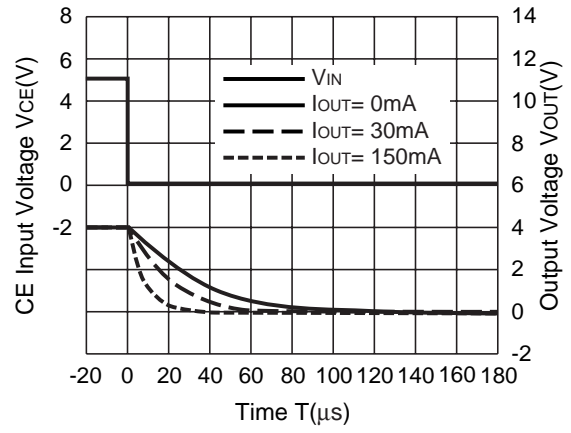
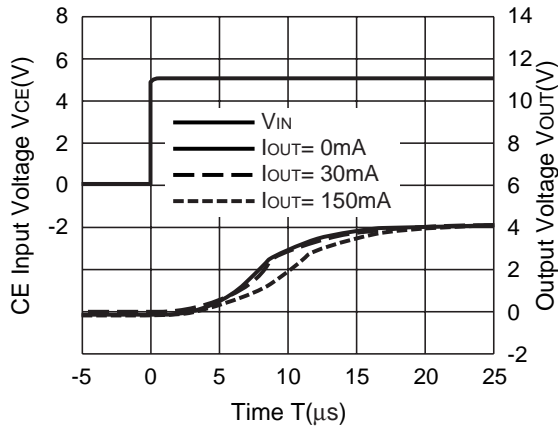

Discontinued Product

ESR vs. Output Current

When using these ICs, consider the following points:

In these ICs, phase compensation is made for securing stable operation even if the load current is varied. For this purpose, use a capacitor C_{OUT} with good frequency characteristics and ESR (Equivalent Series Resistance) of which is in the range described as follows:

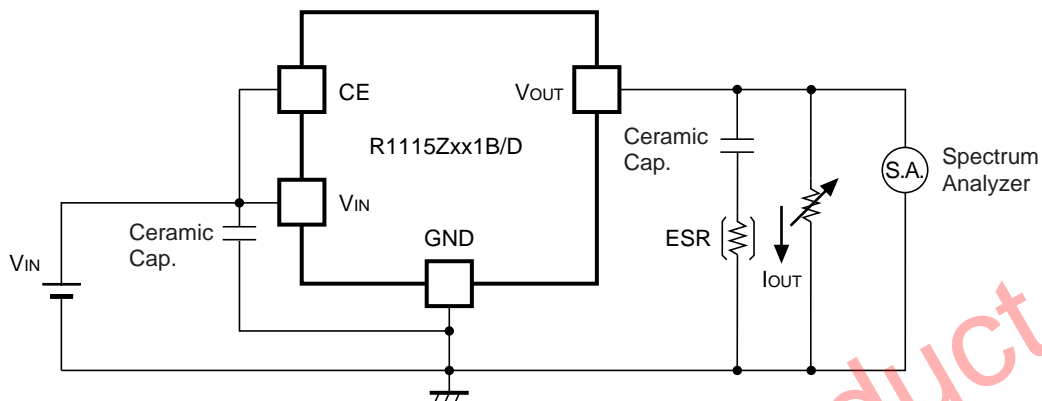

Measuring Circuit for white noise; R1115Zxx1B/D

The relations between I_{OUT} (Output Current) and ESR of an output capacitor are shown below. The conditions when the white noise level is under $40\mu\text{V}$ (Avg.) are marked as the hatched area in the graph.

(Note: If additional ceramic capacitors are connected to the Output Pin with Output capacitor for phase compensation, the operation might be unstable. Because of this, test these ICs with as same external components as ones to be used on the PCB.)

<Measurement conditions>

- (1) $V_{IN} = V_{OUT} + 1\text{V}$
- (2) Frequency Band: 10Hz to 2MHz
- (3) Temperature: -40°C to 25°C

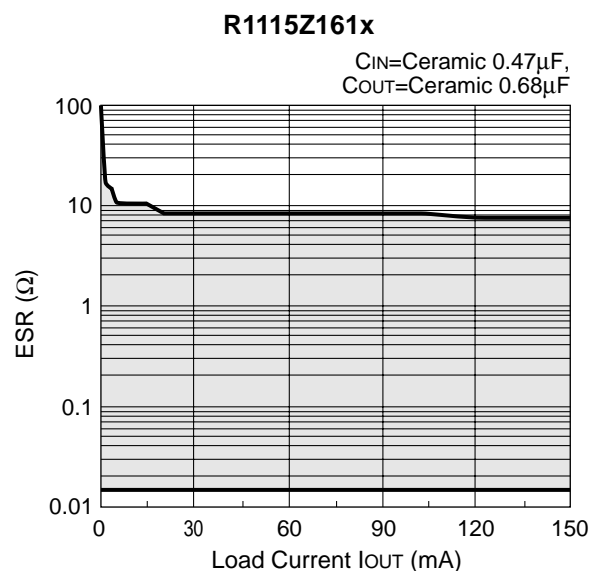
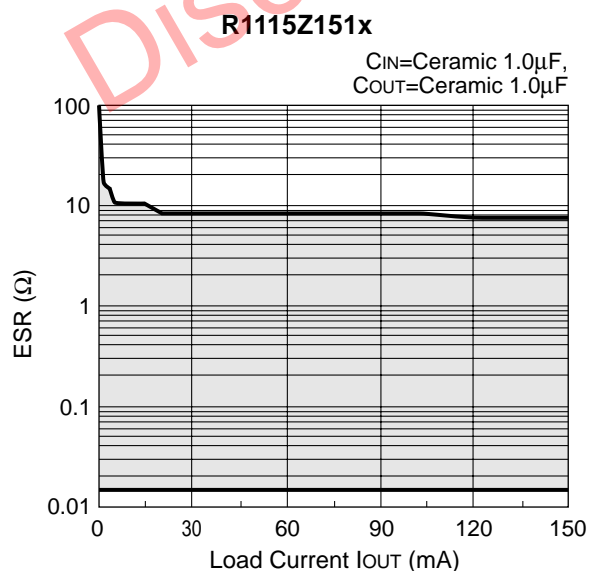

R1115Z211x

C_{IN}=Ceramic 0.47μF,
C_{OUT}=Ceramic 0.47μF

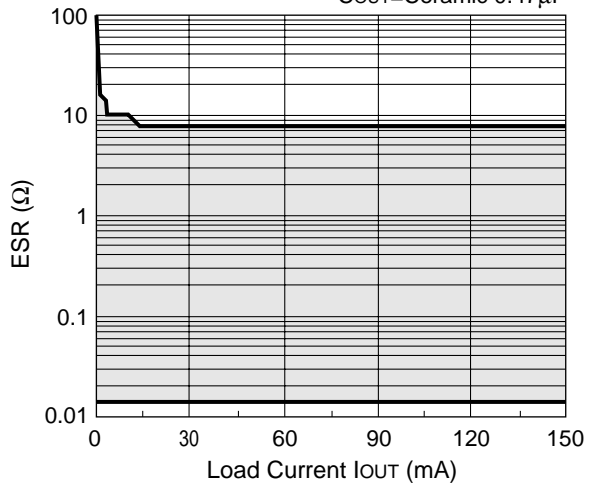

R1115Z281x

C_{IN}=Ceramic 0.47μF,
C_{OUT}=Ceramic 0.47μF

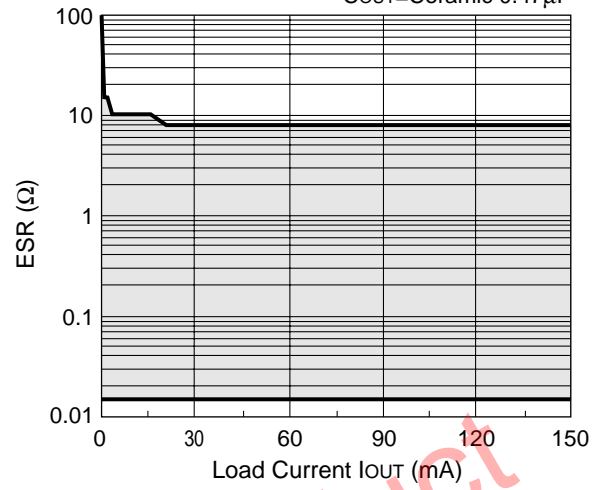

Discontinued Product



1. The products and the product specifications described in this document are subject to change or discontinuation of production without notice for reasons such as improvement. Therefore, before deciding to use the products, please refer to Ricoh sales representatives for the latest information thereon.
2. The materials in this document may not be copied or otherwise reproduced in whole or in part without prior written consent of Ricoh.
3. Please be sure to take any necessary formalities under relevant laws or regulations before exporting or otherwise taking out of your country the products or the technical information described herein.
4. The technical information described in this document shows typical characteristics of and example application circuits for the products. The release of such information is not to be construed as a warranty of or a grant of license under Ricoh's or any third party's intellectual property rights or any other rights.
5. The products listed in this document are intended and designed for use as general electronic components in standard applications (office equipment, telecommunication equipment, measuring instruments, consumer electronic products, amusement equipment etc.). Those customers intending to use a product in an application requiring extreme quality and reliability, for example, in a highly specific application where the failure or misoperation of the product could result in human injury or death (aircraft, spacevehicle, nuclear reactor control system, traffic control system, automotive and transportation equipment, combustion equipment, safety devices, life support system etc.) should first contact us.
6. We are making our continuous effort to improve the quality and reliability of our products, but semiconductor products are likely to fail with certain probability. In order to prevent any injury to persons or damages to property resulting from such failure, customers should be careful enough to incorporate safety measures in their design, such as redundancy feature, fire containment feature and fail-safe feature. We do not assume any liability or responsibility for any loss or damage arising from misuse or inappropriate use of the products.
7. Anti-radiation design is not implemented in the products described in this document.
8. The X-ray exposure can influence functions and characteristics of the products. Confirm the product functions and characteristics in the evaluation stage.
9. WLCSP products should be used in light shielded environments. The light exposure can influence functions and characteristics of the products under operation or storage.
10. There can be variation in the marking when different AOI (Automated Optical Inspection) equipment is used. In the case of recognizing the marking characteristic with AOI, please contact Ricoh sales or our distributor before attempting to use AOI.
11. Please contact Ricoh sales representatives should you have any questions or comments concerning the products or the technical information.



Ricoh is committed to reducing the environmental loading materials in electrical devices with a view to contributing to the protection of human health and the environment.

Ricoh has been providing RoHS compliant products since April 1, 2006 and Halogen-free products since April 1, 2012.

RICOH RICOH ELECTRONIC DEVICES CO., LTD.

<https://www.e-devices.ricoh.co.jp/en/>

Sales & Support Offices

Ricoh Electronic Devices Co., Ltd.

Shin-Yokohama Office (International Sales)

2-3, Shin-Yokohama 3-chome, Kohoku-ku, Yokohama-shi, Kanagawa, 222-8530, Japan
Phone: +81-50-3814-7687 Fax: +81-45-474-0074

Ricoh Americas Holdings, Inc.

675 Campbell Technology Parkway, Suite 200 Campbell, CA 95008, U.S.A.
Phone: +1-408-610-3105

Ricoh Europe (Netherlands) B.V.

Semiconductor Support Centre

Prof. W.H. Keesomlaan 1, 1183 DJ Amstelveen, The Netherlands
Phone: +31-20-5474-309

Ricoh International B.V. - German Branch

Semiconductor Sales and Support Centre

Oberrather Strasse 6, 40472 Düsseldorf, Germany
Phone: +49-211-6546-0

Ricoh Electronic Devices Korea Co., Ltd.

3F, Haesung Bldg, 504, Teheran-ro, Gangnam-gu, Seoul, 135-725, Korea
Phone: +82-2-2135-5700 Fax: +82-2-2051-5713

Ricoh Electronic Devices Shanghai Co., Ltd.

Room 403, No.2 Building, No.690 Bibo Road, Pu Dong New District, Shanghai 201203,
People's Republic of China
Phone: +86-21-5027-3200 Fax: +86-21-5027-3299

Ricoh Electronic Devices Shanghai Co., Ltd.

Shenzhen Branch

1205, Block D (Jinlong Building), Kingkey 100, Hongbao Road, Luohu District,
Shenzhen, China
Phone: +86-755-8348-7600 Ext 225

Ricoh Electronic Devices Co., Ltd.

Taipei office

Room 109, 10F-1, No.51, Hengyang Rd., Taipei City, Taiwan (R.O.C.)
Phone: +886-2-2313-1621/1622 Fax: +886-2-2313-1623