

# 3.5V to 60V, 2.5A/3A, Synchronous Step-Down Regulator

## 1 FEATURES

- Automotive AEC-Q100 Grade 1 Compliance
- Ultra-Low Quiescent Current 27 $\mu$ A in Regulation
- Wide  $V_{IN}$  Range: 3.5V to 60V
- Wide  $V_{OUT}$  Range: 1V to  $V_{IN}$
- Integrated both High-Side and Low-Side Power MOSFETs with up to 2.5A/3A Output Capability
- Programmable Fixed Frequency Range: 200kHz to 2.5MHz
- PLL Synchronization to External Clock
- Adjustable Soft Start and Tracking Capability
- High Efficiency Low Load DCM and PFM Operation
- Automatic Transition into Bypass LDO to Increase Low-Load Efficiency
- Near 100% Duty Cycle Operation for Low Drop Out Operation
- Low Minimum On-Time: 109 ns
- Accurate Peak and Valley Clamp and Protection
- Internal Compensation
- Spread Spectrum for Low EMI Applications
- Power Good Indicator
- Accurate VIN UVLO Protection
- Over-Temperature Shutdown and Recovery
- Output Short-Circuit Protection with Hiccup Mode
- Thermally Enhanced TSSOP-EP16 Package (5mm X 4.4mm X 1.2mm)

## 2 APPLICATIONS

- Automotive Power Supplies
- Industrial Power Supplies
- Battery Powered Systems

## 3 DESCRIPTION

The LN10X62/3Q1 is a high efficiency, compact, synchronous step-down DC-DC converter employing a constant frequency, peak current mode control architecture with internal compensation. It operates from an input voltage from 3.5V to 60V, provides an adjustable output voltage from 1V to  $V_{IN}$ . LN10X62Q1 can deliver to 2.5A of output current, while LN10X63Q1 can deliver up to 3.0A. The switching frequency range is from 200kHz to 2.5MHz.

**Device Information Table**

Part Number	Package	Dimension
LN10062Q1	TSSOP-EP16	5mm x 4.4mm x 1.2mm
LN10063Q1	TSSOP-EP16	5mm x 4.4mm x 1.2mm
LN10162Q1	TSSOP-EP16	5mm x 4.4mm x 1.2mm
LN10163Q1	TSSOP-EP16	5mm x 4.4mm x 1.2mm

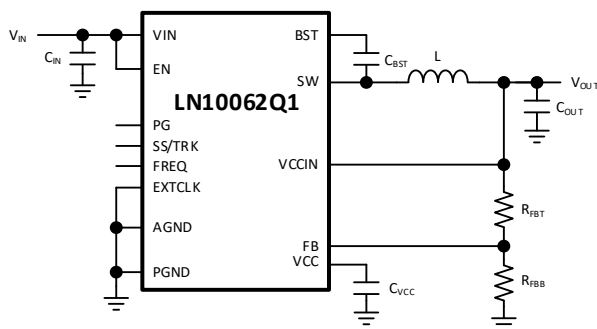

**LN10062Q1 Typical Application Diagram**

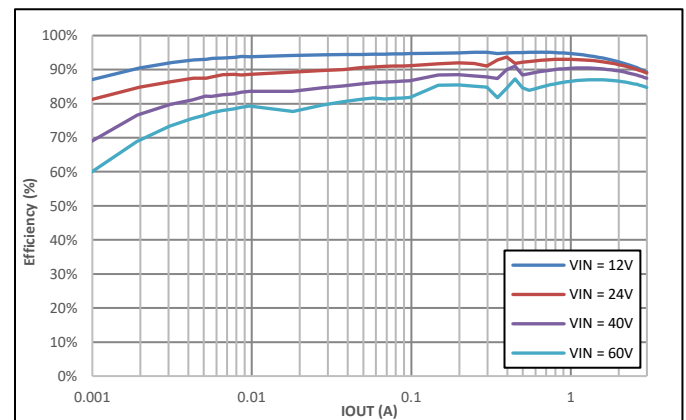

**LN10063Q1 400kHz Efficiency Chart**

## Table of Contents

1	FEATURES .....	1
2	APPLICATIONS .....	1
3	DESCRIPTION .....	1
4	REVISION HISTORY .....	4
5	ORDER INFORMATION .....	5
6	PIN CONFIGURATION .....	6
6.1	Pin Configuration .....	6
6.2	Pin Functions.....	6
6.3	Package Thermal Parameters .....	7
7	SPECIFICATIONS .....	8
7.1	Absolute Maximum Ratings.....	8
7.2	ESD Ratings .....	8
7.3	Recommended Operating Condition.....	9
7.4	Electrical Characteristics .....	10
7.5	Typical Characteristics .....	14
8	FUNCTIONAL DESCRIPTION.....	20
8.1	Overview .....	20
8.2	Functional Diagram .....	21
8.3	Application Diagram with Full Features.....	21
8.4	Functional Description.....	22
9	APPLICATION INFORMATION.....	28
9.1	Typical Applications .....	28
9.2	Typical External Components .....	30
10	LAYOUT .....	31
10.1	Layout Guidelines .....	31
10.2	Layout Example.....	32
11	PACKAGE INFORMATION .....	33
11.1	Package Outline .....	33
11.2	Footprint Example .....	34

**IMPORTANT NOTICE AND DISCLAIMERS** ..... 35

**ENVIRONMENTAL DECLARATION** ..... 35

#### 4 REVISION HISTORY

Version	Change Description	Date
1.0	Initial Version	2020/07/16
1.1	Update Chapter 7.1 Table “Absolute Maximum Ratings”.....P8	2020/10/10
1.2	Update Table “order information”.....P5 Update conditions of $I_{Q-NONSW}$ , $I_{VCCIN-NONSW}$ and $I_{SHDN}$ , add maximum data.....P10 Update conditions of $V_{FB-CCM}$ .....P10 Update typical and maximum of $I_{Q-FB}$ .....P10 Update maximum and minimum of EN parameters.....P11 Update maximum and minimum of $V_{CCIN-ON}$ .....P12 Update description of PG parameters.....P13 Update maximum and minimum of SS parameters.....P13 Update efficiency and regulation curves.....P14 Update conditions of EMI curves.....P19 Update package information.....P33	2021/08/31
1.3	Update package information.....P33	2022/04/26

**5 ORDER INFORMATION**

Device	Output Current	Spread Spectrum	IC Package	MSL-Peak-Temp <sup>(1)</sup>	Material	Package	Package Qty	Top Marking <sup>(2)</sup>
LN10062Q1-AKR	2.5A	No	TSSOP-EP16	Level-3-260C	RoHS	Tape & Reel	3000	See illustration
LN10063Q1-AKR	3A	No	TSSOP-EP16	Level-3-260C	RoHS	Tape & Reel	3000	See illustration
LN10162Q1-AKR	2.5A	Yes	TSSOP-EP16	Level-3-260C	RoHS	Tape & Reel	3000	See illustration
LN10163Q1-AKR	3A	Yes	TSSOP-EP16	Level-3-260C	RoHS	Tape & Reel	3000	See illustration

(1) MSL (Moisture Sensitivity Level) and the highest solder temperature are based on JEDEC industrial standard.

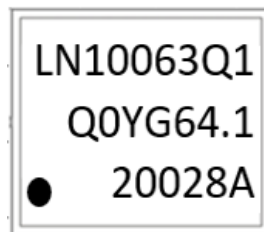

Line 1: Product Mark Code

Line 2: Lot ID

Line 3: Date Code

## 6 PIN CONFIGURATION

### 6.1 Pin Configuration

TSSOP-EP16 (5mm X 4.4mm X 1.2mm)

Top View

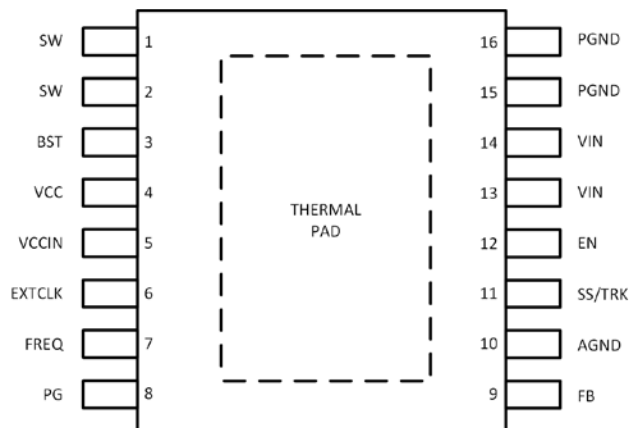

### 6.2 Pin Functions

Name	PIN Number	Type	Description
SW	1,2	Power	Switch node connection from the internal power MOSFETs to the external inductor.
BST	3	Power	Bootstrapped supply to the high side gate driver. Connect a 100nF ceramic capacitor between BST and SW pins.
VCC	4	Power	Voltage source that powers the gate drivers of the internal power MOSFETs and control circuits. Must be decoupled to PGND with 1-4.7 $\mu$ F ceramic capacitor. This voltage source is provided by one of the two internal LDO regulators with input from $V_{IN}$ or $V_{CCIN}$ .
VCCIN	5	Power	External power input to an auxiliary internal $V_{CCIN}$ LDO regulator. This LDO supplies $V_{CC}$ power from $V_{CCIN}$ , bypassing the internal $V_{IN}$ LDO regulator powered from $V_{IN}$ when $V_{CCIN}$ is above the switchover threshold.
EXTCLK	6	Signal	External synchronization clock input.
FREQ	7	Signal	Switching frequency control pin. Place a resistor between this pin and AGND to set the switching frequency between 200kHz and 2.5MHz.
PG	8	Signal	Open-drain power good output. $V_{FB}$ is monitored and when $V_{FB}$ is not within the regulation window. PG pin is pulled low.
FB	9	Signal	Output voltage feedback input. Use an external divider to set the desired output voltage.
AGND	10	Ground	Analog ground.

SS/TRK	11	Signal	Soft-start and tracking pin. The voltage on this pin sets the limit for internal reference voltage for regulation target. To use the internal soft-start ramp, leave this pin open. A capacitor between this pin and the analog ground sets the ramp time for output voltage during startup. This pin can also be driven by an external voltage ramp. When the external voltage is less than the internal ramp voltage, the output voltage tracks the external voltage ramp.
EN	12	Signal	Enable pin for V <sub>CC</sub> LDOs, regulator output, and input voltage for V <sub>IN</sub> UVLO. Connect to V <sub>IN</sub> directly, to V <sub>IN</sub> through a divider, or to an external voltage source.
VIN	13,14	Power	Power supply input pin to high side power MOSFET and V <sub>IN</sub> LDO regulator. Decouple this pin to PGND with ceramic capacitors.
PGND	15,16	Ground	Power ground. Connect the pins to ground plane.
THERMAL PAD	-	-	Thermal dissipation pad. Solder to ground plane.

### 6.3 Package Thermal Parameters

Parameter <sup>(1)</sup>		TSSOP-EP16	Units
R <sub>θJA</sub>	Junction-to-Ambient Thermal Resistance	38	°C/W
ψ <sub>JT</sub>	Junction-to-Top Characterization Parameter	3	°C/W

(1) Measurements are based on standard 2s2p PCB defined in JESD 51-7 2s2p, under no wind, 2W loss, and 25 °C ambient temperature.

## 7 SPECIFICATIONS

### 7.1 Absolute Maximum Ratings

Parameters	Min	Max	Unit
VIN to PGND	-0.3	65	V
EN to PGND	-0.3	V <sub>IN</sub>	
FB, FREQ, SS/TRK to AGND	-0.3	V <sub>CC</sub>	
PG to AGND	-0.3	36	
EXTCLK to AGND	-0.3	5.5	
VCCIN to PGND	-0.3	36	
VCC to PGND	-0.3	5.5	
SW to PGND	-1.0	V <sub>IN</sub> +0.3	
SW to PGND (Overshoot voltage less than 10ns)	-3.5	65	
BST to SW	-0.3	5.5	
AGND to PGND	-0.3	0.3	
Ambient Temperature	-40	125	°C
Junction Temperature	-40	150	
Storage Temperature	-65	150	

### 7.2 ESD Ratings

Parameters	Min	Max	Unit
HBM Human Body Model		±3000	V
CDM Charge Device Model		±1000	



**7.3 Recommended Operating Condition**

Parameters	Min	Max	Unit
VIN	3.5	60	V
EN	-0.3	V <sub>IN</sub>	
FB	-0.3	1.1	
PG	-0.3	30	
EXTCLK	-0.3	5.5	
VCCIN	-0.3	30	
AGND to PGND	-0.1	0.1	
Output voltage	1	V <sub>IN</sub>	
LN10X62Q1 output current	0	2.5	A
LN10X63Q1 output current	0	3	A
Ambient temperature	-40	125	°C
Junction temperature	-40	125	

## 7.4 Electrical Characteristics

Unless otherwise stated, the minimum and maximum limits apply over the recommended operating junction temperature range of -40°C to 125°C. Typical values are measured at 25°C and represent the most likely norm. The default conditions apply:  $V_{IN} = 24V$ ,  $V_{OUT} = 5V$ ,  $F_S = 400kHz$ .

SYMBOL	PARAMETER	CONDITION	MIN	TYP	MAX	UNIT
<b>SUPPLY VOLTAGE, VOUT (VIN PINS)</b>						
$V_{IN}$	Operating Input Voltage Range		3.5		60	V
$V_{OUT}$	Operating Output Voltage Range		1		$V_{IN}$	V
$I_{Q-NONSW}$	VIN Supply Current	$V_{EN} = 3.3V$ , $V_{FB} = 1.5V$ , $V_{CCIN} = 3.4V$ external $V_{IN} = 24V$		4.25	6.8	$\mu A$
$I_{VCCIN-NONSW}$	VCCIN Supply Current	$V_{EN} = 3.3V$ , $V_{FB} = 1.5V$ , $V_{CCIN} = 3.4V$ external $V_{IN} = 24V$		58	77	$\mu A$
$I_Q$	During Regulation	$V_{EN} = V_{IN} = 24V$ , $V_{CCIN} = V_{OUT} = 5V$ , $I_{OUT} = 0A$		27		$\mu A$
$I_{SHDN}$	Shutdown Quiescent Current	$V_{EN} = 0V$ , $V_{IN} = 24V$		1.3	2.2	$\mu A$
<b>FB PIN</b>						
$V_{FB-CCM}$	Regulated Feedback Voltage in CCM Mode	$V_{IN} = 24V$ , @25C	0.992	1.0	1.008	V
		Full $V_{IN}$ Range, Full Load Range, Full Operational Temperature Range	0.98	1.0	1.02	V
$I_{Q-FB}$	Feedback Input Leakage Current	$V_{FB} = 1.0V$		0	100	nA
<b>POWER MOSFETS</b>						
$R_{DSON-HS}^{(1)}$	High Side MOSFET ON Resistance	$I_{OUT} = 1A$ , $V_{BST} - V_{SW} = 5V$		180		m $\Omega$
$R_{DSON-LS}^{(1)}$	Low Side MOSFET ON Resistance	$I_{OUT} = 1A$ , $V_{CC} = 5V$		101		m $\Omega$
<b>PWM</b>						
$T_{ON-MIN}$	Minimum ON Time			109		ns
$T_{OFF-MIN}$	Minimum OFF Time			134		ns

(1) Measured at pins.

**Electrical Characteristics (Continued)**

Unless otherwise stated, the minimum and maximum limits apply over the recommended operating junction temperature range of -40°C to 125°C. Typical values are measured at 25°C and represent the most likely norm. The default conditions apply:  $V_{IN} = 24V$ ,  $V_{OUT} = 5V$ ,  $F_S = 400kHz$ .

<b>OSCILLATOR (FREQ PIN)</b>					
$F_{OSC-INT}$	Default Frequency	FREQ Pin Floating	400		kHz
$F_{OSC-400kHz}$	Default Frequency	$R_{FREQ} = 210k\Omega$	350	400	450
$F_S$	Adjustable Frequency Range	With 1% Resistor at FREQ Pin	0.2		2.5
<b>SYNCHRONIZATION (EXTCLK PIN)</b>					
$F_{EXTCLK}$	EXTCLK Frequency Range		0.2		2.5
$V_{EXTCLK-HIGH}$	EXTCLK High-Level Threshold		2.0		V
$V_{EXTCLK-LOW}$	EXTCLK Low-Level Threshold		0.4		V
$D_{EXTCLK-MAX}$	EXTCLK Maximum Duty Cycle		90%		%
$D_{EXTCLK-MIN}$	EXTCLK Minimum Duty Cycle		10%		%
$T_{EXTCLK-MIN}$	Minimum EXTCLK ON and OFF Time		80		ns
<b>SPREAD SPECTRUM MODULATION <sup>(2)</sup></b>					
$\Delta F_S$	Spread Spectrum Modulation Frequency Range		-18		%
$F_{SSM}$	Spread Spectrum Modulation Frequency		16		kHz
<b>ENABLE <math>V_{IN}</math> UVLO (EN PIN)</b>					
$EN_{VCC-ON}$	$V_{EN}$ High-Level Threshold	$V_{EN}$ Rising	1.83		V
$EN_{VCC-OFF}$	$V_{EN}$ Low-Level Threshold	$V_{EN}$ Falling	0.4		V
$EN_{VOUT-ON}$	$V_{IN}$ UVLO Rising Threshold	$V_{EN}$ Rising	1.92	2.08	2.25
$EN_{VOUT-HYS}$	$V_{IN}$ UVLO Hysteresis	$V_{EN}$ Falling	-200		mV
$I_{Q-EN}$	EN Pin Current	$V_{EN} = 3.3V$	0		0.2

(2) This Function is available on LN1016XQ1 Only.

**Electrical Characteristics (Continued)**

Unless otherwise stated, the minimum and maximum limits apply over the recommended operating junction temperature range of -40°C to 125°C. Typical values are measured at 25°C and represent the most likely norm. The default conditions apply:  $V_{IN} = 24V$ ,  $V_{OUT} = 5V$ ,  $F_S = 400kHz$ .

<b>INTERNAL VCC LDOS (VCC, VCCIN, AND VIN PINS)</b>						
$V_{CC-TARGET}$	$V_{CC}$ Regulation Target		4.75		V	
$V_{CC-UVLO-H}$	$V_{CC}$ UVLO Rising Threshold	$V_{CCIN}$ Rising	2.59	2.75	2.90	V
$V_{CC-UVLO-L}$	$V_{CC}$ UVLO Falling Threshold	$V_{CCIN}$ Falling	2.45	2.60	2.71	V
$V_{CCIN-ON}$	$V_{CCIN}$ Switchover Rising Threshold	$V_{CCIN}$ Rising	2.72	3.0	3.14	V
	$V_{CCIN}$ Switchover Hysteresis	Hysteresis	-100			mV
<b>BOOTSTRAP (BST PIN)</b>						
$t_{REFRESH-PER}$	Auto-Refresh Period		26			$\mu s$
<b>OVER CURRENT PROTECTION <sup>(3)</sup></b>						
$I_{LIM-PEAK-2.5A}$	Peak Current Limit Threshold	LN10X62Q1	4.2			A
$I_{LIM-VALLEY-2.5A}$	Valley Current Limit Threshold		2.7			A
$I_{LIM-PEAK-3A}$	Peak Current Limit Threshold	LN10X63Q1	4.7			A
$I_{LIM-VALLEY-3A}$	Valley Current Limit Threshold		3.2			A
<b>THERMAL SHUTDOWN <sup>(4)</sup></b>						
$OT$	Thermal Shutdown Threshold		160			°C
$OT_{HYS}$	Thermal Shutdown Recovery Hysteresis		-10			°C

(3) The current limits are measured in close-loop regulation with typical application in Figure 38. Due to inherent delays in the current limit comparators and drivers, the current limits measured in other applications may be different.

(4) Guaranteed by design.

**Electrical Characteristics (Continued)**

Unless otherwise stated, the minimum and maximum limits apply over the recommended operating junction temperature range of  $-40^{\circ}\text{C}$  to  $125^{\circ}\text{C}$ . Typical values are measured at  $25^{\circ}\text{C}$  and represent the most likely norm. The default conditions apply:  $V_{\text{IN}} = 24\text{V}$ ,  $V_{\text{OUT}} = 5\text{V}$ ,  $F_{\text{S}} = 400\text{kHz}$ .

<b>POWER GOOD (PG AND FB PINS) <sup>(5)</sup></b>						
$V_{\text{PG-OV}}$	Power Good Over-Voltage Rising Threshold	$V_{\text{FB}}$ Ramping Up	111%	118%		%
$V_{\text{PG-UV}}$	Power Good Under-Voltage Falling Threshold	$V_{\text{FB}}$ Ramping Down	81%	87%		%
$V_{\text{PG-OV-HYS}}$	Power Good Over-Voltage Recovery Hysteresis	% of FB voltage	3.7%			
$V_{\text{PG-UV-HYS}}$	Power Good Under-Voltage Recovery Hysteresis	% of FB voltage	3.7%			
$V_{\text{PG-PD}}$	Power Good Pull-Down Strength	$I_{\text{PG}} = 1\text{mA}$	40			mV
$t_{\text{PG-RISING}}$	Power Good Flag Rising Delay		320			$\mu\text{s}$
$t_{\text{PG-FALLING}}$	Power Good Flag Falling Delay		320			$\mu\text{s}$
$I_{\text{Q-PG}}$	PG Leakage Current	$V_{\text{PG}} = 5\text{V}$	10			nA
<b>SOFT START, TRACKING (SS/TRK PIN)</b>						
$t_{\text{SS-INT}}^{(6)}$	Internal Soft-Start Time	SS Pin Float	2.4	5.1	8.4	ms
$I_{\text{SS-CHARGE}}$	Soft-Start Charge Current	$V_{\text{SS}} = 0\text{V}$	1.76	2.6	3.6	$\mu\text{A}$
$R_{\text{SS-DISCHARGE}}$	Soft-Start Discharge Resistance	$V_{\text{CCIN}} = 0\text{V}$ $V_{\text{IN}} = 24\text{V}$	6.8	7.5	8.9	k $\Omega$

(5) Power Good Thresholds are parameters of VFB with respect to  $V_{\text{FB-CCM}}$

(6) Measured from  $\text{EN}_{\text{VOUT-ON}}$  to soft start done.

## 7.5 Typical Characteristics

### 7.5.1 Characteristics Over Temperature

Unless otherwise stated, the test conditions are the same as Chapter 7.4.  $T_J = -40^{\circ}\text{C}$  到  $125^{\circ}\text{C}$ .

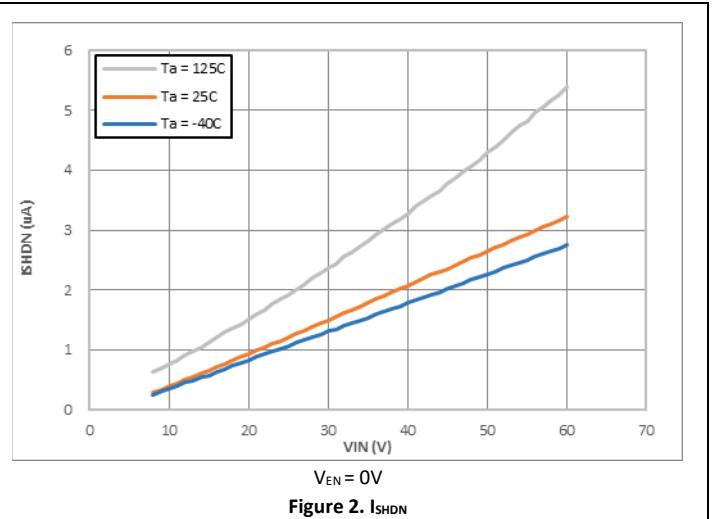
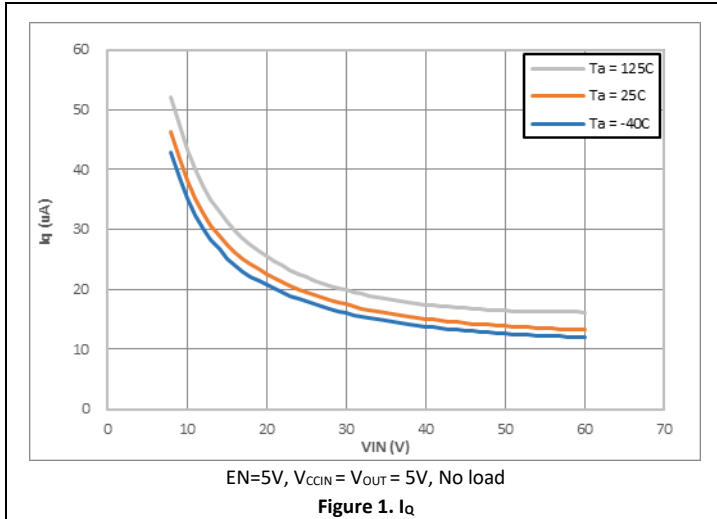

### 7.5.2 Typical Characteristics

Unless otherwise stated, the test conditions are:  $V_{IN} = 24V$ ,  $V_{CCIN} = V_{OUT} = 5V$ ,  $F_S = 400\text{kHz}$ ,  $L = 10\mu\text{H}$ ,  $T_A = 25^{\circ}\text{C}$ .

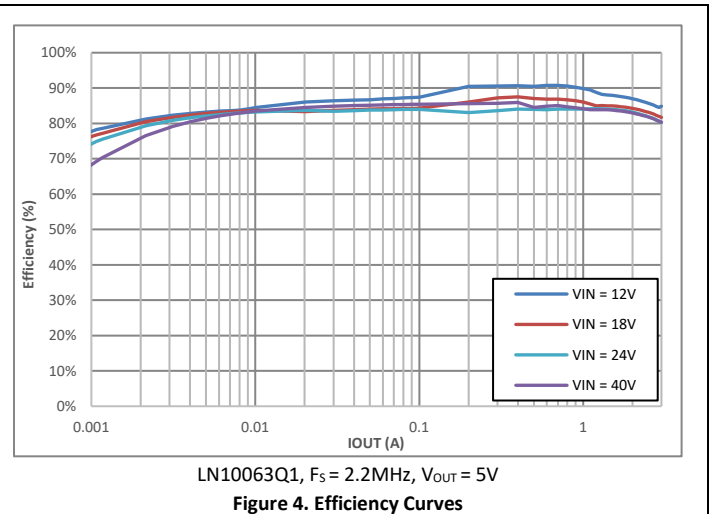
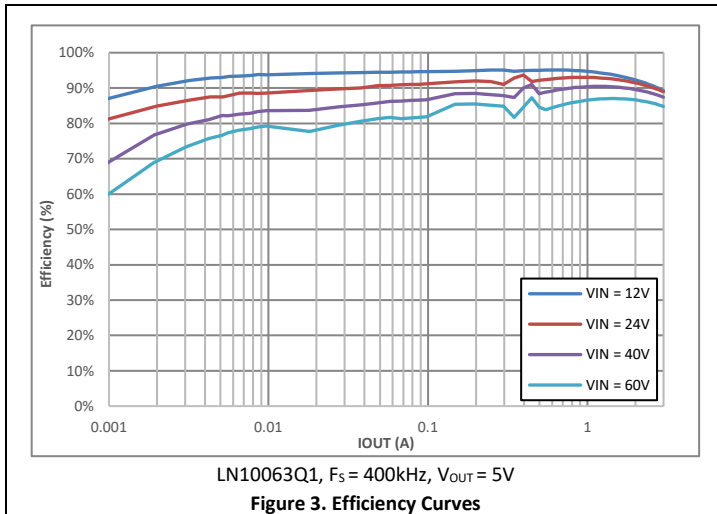

Typical Characteristics (Continued)

Unless otherwise stated, the test conditions are:  $V_{IN} = 24V$ ,  $V_{CCIN} = V_{OUT} = 5V$ ,  $F_s = 400kHz$ ,  $L = 10\mu H$ ,  $T_A = 25^\circ C$ .

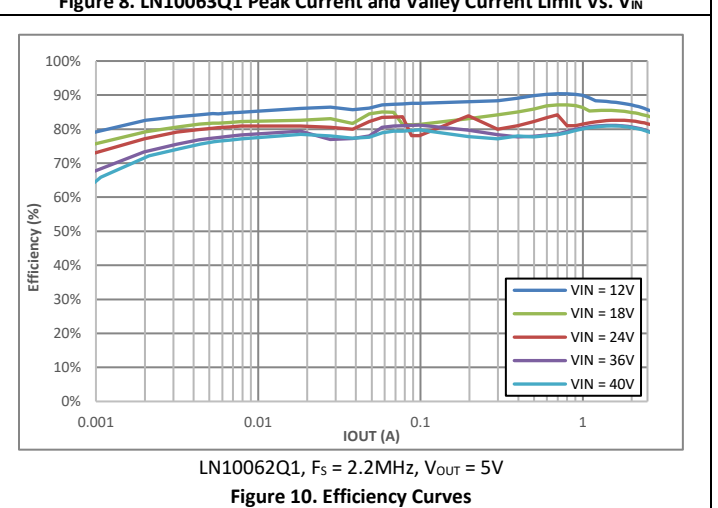
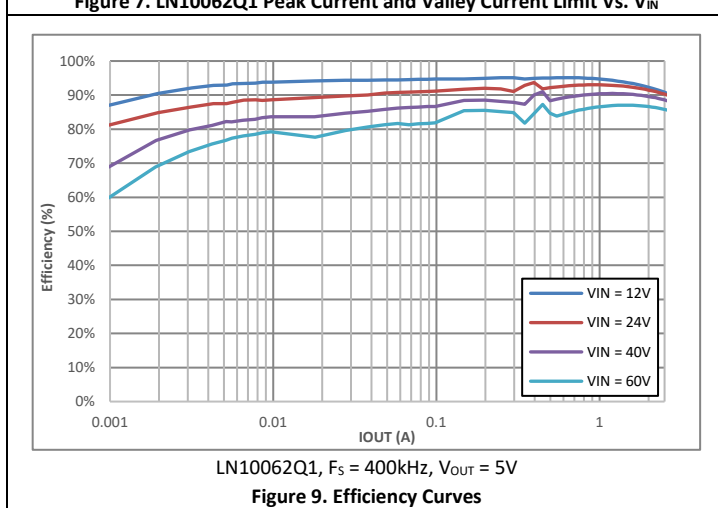
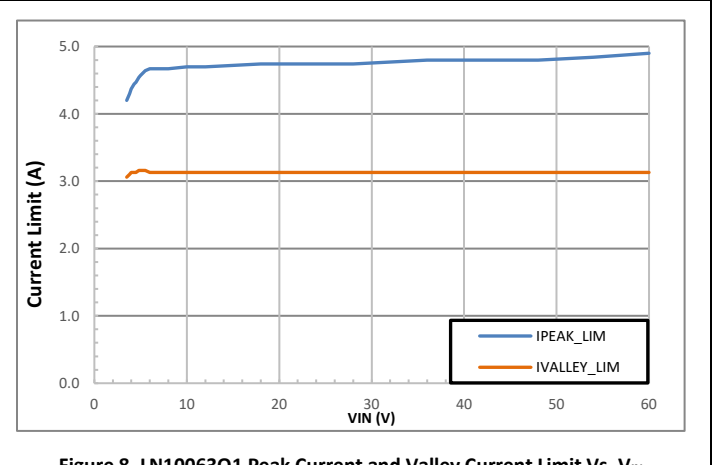
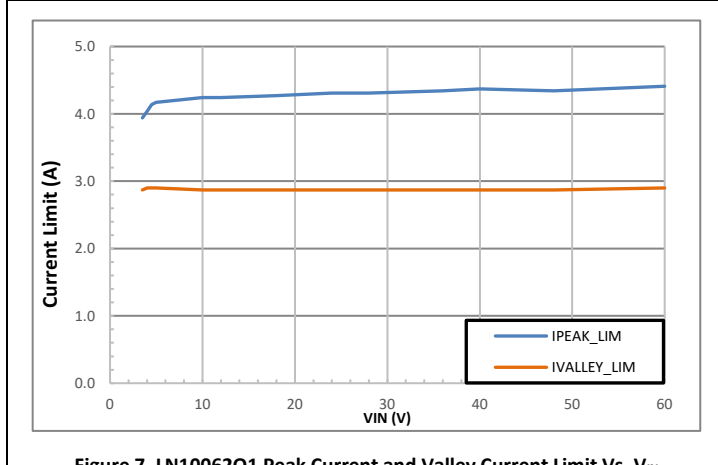
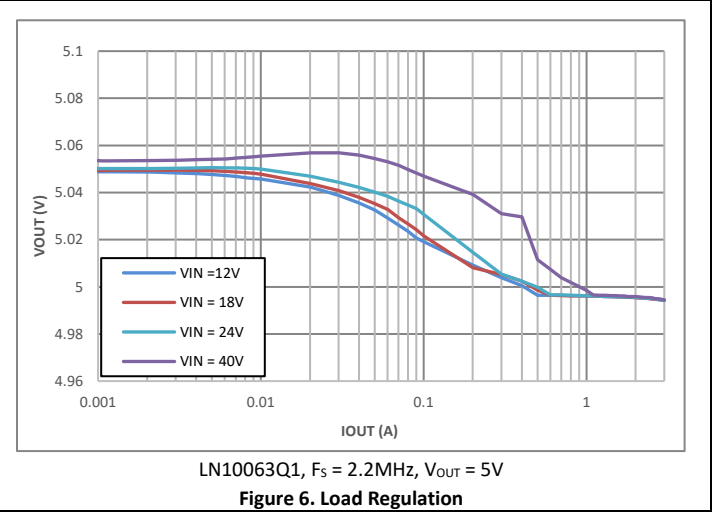
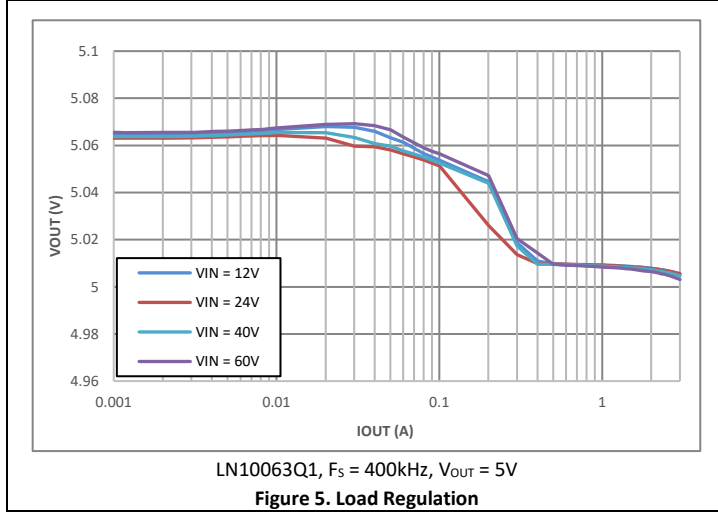

### 7.5.3 Typical Waveforms

Unless otherwise stated, the test conditions are:  $V_{IN} = 24V$ ,  $V_{CCIN} = V_{OUT} = 5V$ ,  $F_S = 400kHz$ ,  $L = 10\mu H$ ,  $T_A = 25^\circ C$ .

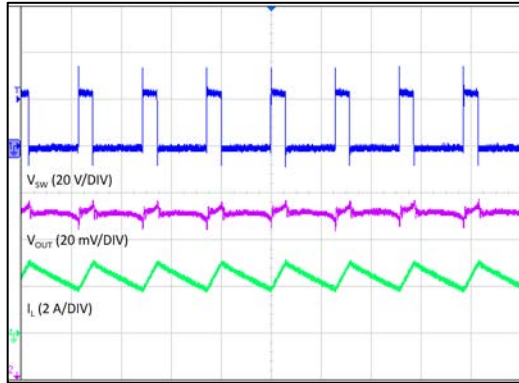

Time (2  $\mu s$ /DIV)

$F_S = 400kHz$ ,  $V_{IN} = 24V$ ,  $V_{OUT} = 5V$ ,  $I_{OUT} = 2.5A$

Figure 11. Switching Waveform in PWM Operation

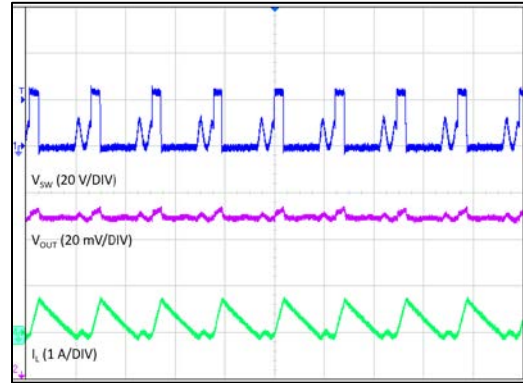

Time (2  $\mu s$ /DIV)

$F_S = 400kHz$ ,  $V_{IN} = 24V$ ,  $V_{OUT} = 5V$ ,  $I_{OUT} = 250mA$

Figure 12. Switching Waveform in PWM with DCM Operation

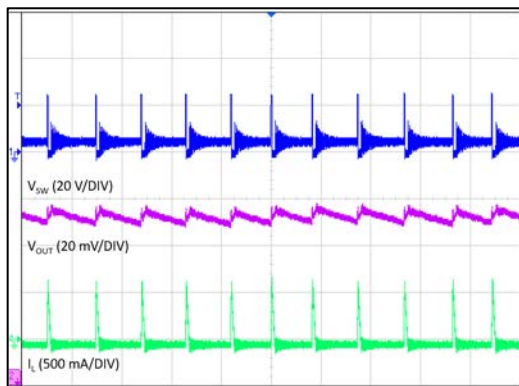

Time (20  $\mu s$ /DIV)

$V_{IN} = 24V$ ,  $V_{OUT} = 5V$ ,  $I_{OUT} = 25mA$

Figure 13. Switching Waveform in PFM Operation

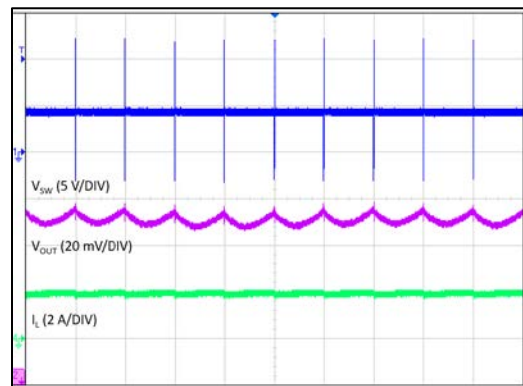

Time (20  $\mu s$ /DIV)

$V_{IN} = 5V$ ,  $V_{OUT} = 5V$ ,  $I_{OUT} = 2A$

Figure 14. Switching Waveform in Dropout Operation

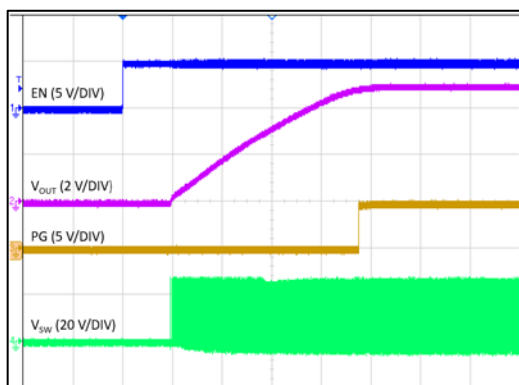

Time (1 ms/DIV)

$V_{IN} = 24V$ ,  $V_{OUT} = 5V$ ,  $R_{LOAD} = 2\Omega$

Figure 15. Startup through EN

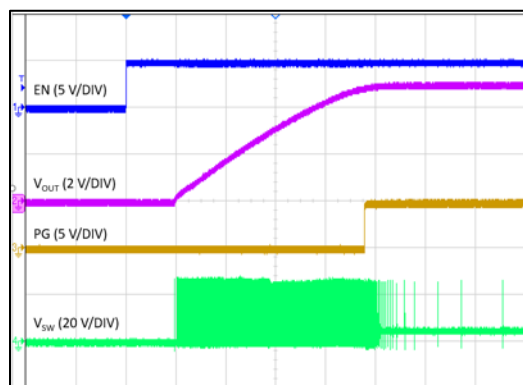

Time (1 ms/DIV)

$V_{IN} = 24V$ ,  $V_{OUT} = 5V$ ,  $I_{OUT} = 0A$

Figure 16. Startup through EN



Typical Waveforms (Continued)

Unless otherwise stated, the test conditions are:  $V_{IN} = 24V$ ,  $V_{CCIN} = V_{OUT} = 5V$ ,  $F_S = 400kHz$ ,  $L = 10\mu H$ ,  $T_A = 25^\circ C$ .

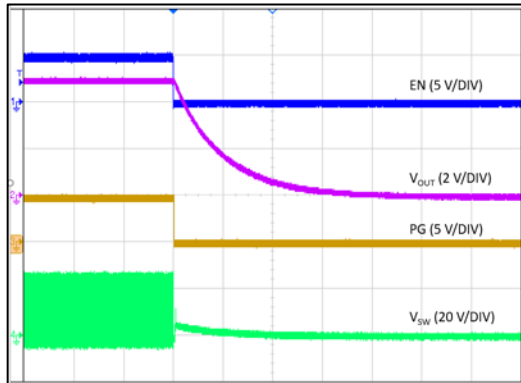

Time (200  $\mu s$ /DIV)  
 $V_{IN} = 24V$ ,  $V_{OUT} = 5V$ ,  $R_{LOAD} = 2\Omega$   
**Figure 17. Shutdown through EN**

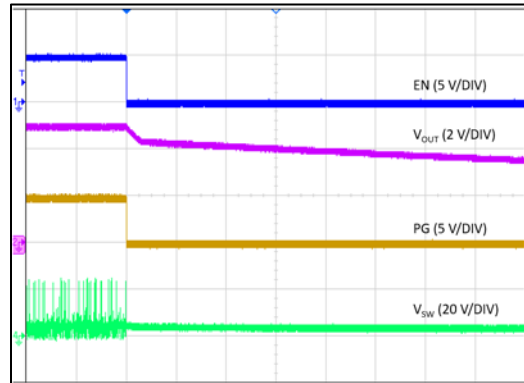

Time (500 ms/DIV)  
 $V_{IN} = 24V$ ,  $V_{OUT} = 5V$ ,  $I_{OUT} = 0A$   
**Figure 18. Shutdown through EN**

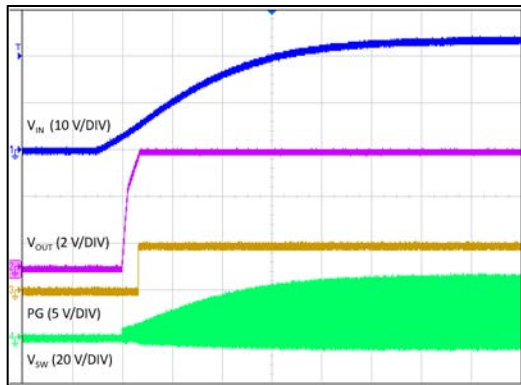

Time (20 ms/DIV)  
 $V_{IN} = 24V$ ,  $V_{OUT} = 5V$ ,  $R_{LOAD} = 2\Omega$   
**Figure 19. Startup (EN tight to  $V_{IN}$ )**

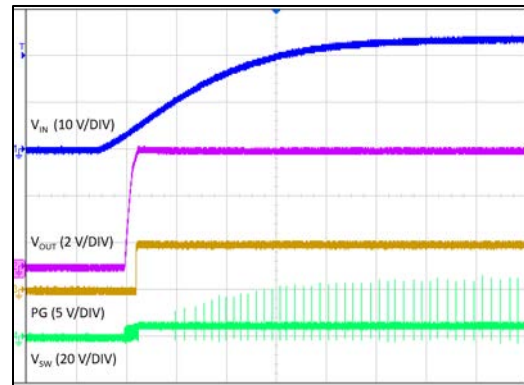

Time (20 ms/DIV)  
 $V_{IN} = 24V$ ,  $V_{OUT} = 5V$ ,  $I_{OUT} = 0A$   
**Figure 20. Startup (EN tight to  $V_{IN}$ )**

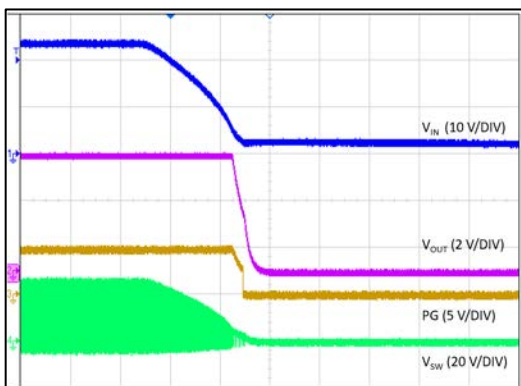

Time (2 ms/DIV)  
 $V_{IN} = 24V$ ,  $V_{OUT} = 5V$ ,  $R_{LOAD} = 2\Omega$   
**Figure 21. Shutdown (EN tight to  $V_{IN}$ )**

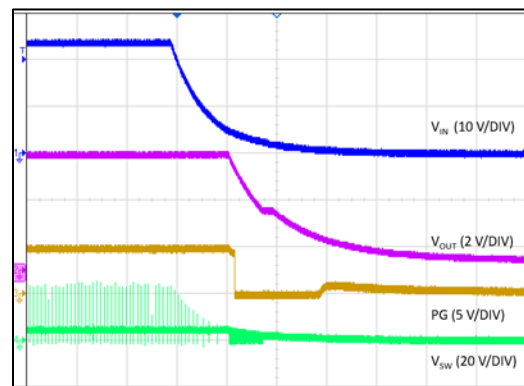

Time (50 ms/DIV)  
 $V_{IN} = 24V$ ,  $V_{OUT} = 5V$ ,  $I_{OUT} = 0A$   
**Figure 22. Shutdown (EN tight to  $V_{IN}$ )**

Typical Waveforms (Continued)

Unless otherwise stated, the test conditions are:  $V_{IN} = 24V$ ,  $V_{CCIN} = V_{OUT} = 5V$ ,  $F_S = 400kHz$ ,  $L = 10\mu H$ ,  $T_A = 25^\circ C$ .

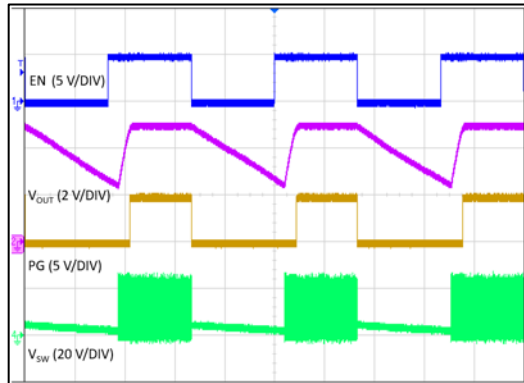

Time (10 ms/DIV)  
 $V_{IN} = 24V$ ,  $I_{OUT} = 10mA$

Figure 23. Startup with Pre-Charged Voltage

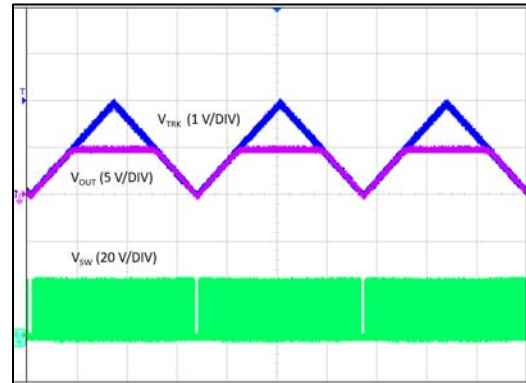

Time (10 ms/DIV)  
 $V_{IN} = 24V$ ,  $R_{LOAD} = 2\Omega$

Figure 24. Tracking External Voltage

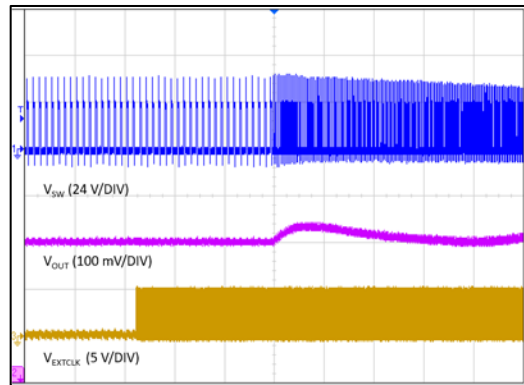

Time (20  $\mu s$ /DIV)  
 $V_{IN} = 24V$ ,  $V_{OUT} = 5V$ ,  $R_{LOAD} = 2\Omega$

Figure 25. Synced into External 2MHz Clock

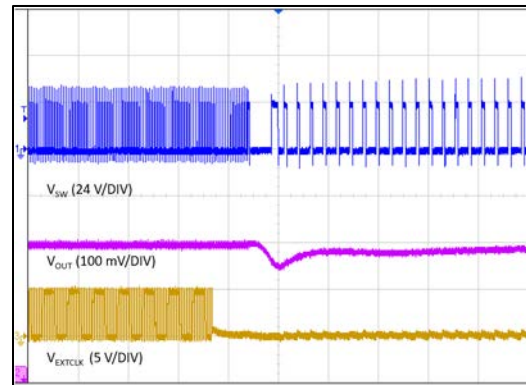

Time (10  $\mu s$ /DIV)  
 $V_{IN} = 24V$ ,  $V_{OUT} = 5V$ ,  $R_{LOAD} = 2\Omega$

Figure 26. Synced out of External 2MHz Clock

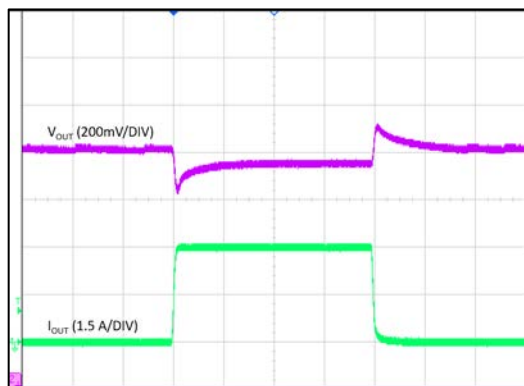

Time (100us/DIV)  
 $V_{IN} = 24V$ ,  $V_{OUT} = 5V$

Figure 27. Load Transient 0.0 <-> 3.0A

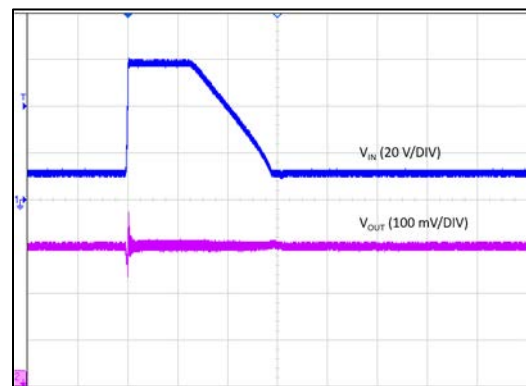

Time (500  $\mu s$ /DIV)  
 $V_{OUT} = 5V$ ,  $I_{OUT} = 2.5A$

Figure 28.  $V_{IN}$  Transient 12V <-> 60V

**Typical Waveforms (Continued)**

Unless otherwise stated, the test conditions are:  $V_{IN} = 24V$ ,  $V_{CCIN} = V_{OUT} = 5V$ ,  $F_S = 400kHz$ ,  $L = 10\mu H$ ,  $T_A = 25^\circ C$ .

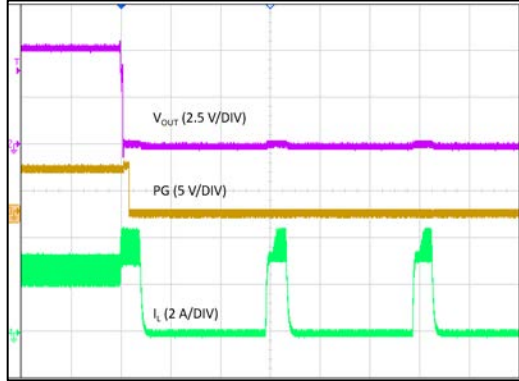

Time (2 ms/DIV)  
**Figure 29. Into Output Short and Hiccup**

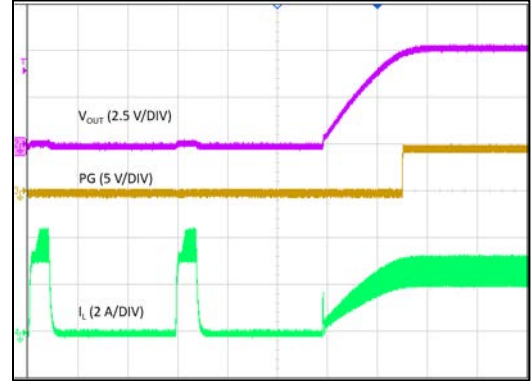

Time (2 ms/DIV)  
**Figure 30. Out of Output Short and Recovery**

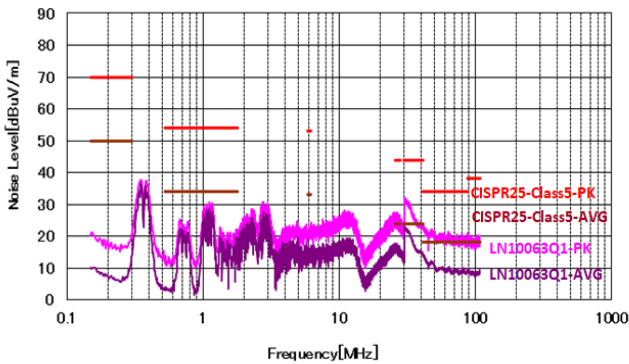

**Figure 31. Conducted EMI Performance (CISPR25 Conductive Emission Test with Class 5 Limits, P(+))**  
LN10163Q1,  $V_{IN} = 12V$ ,  $I_{OUT} = 3A$ ,  $F_S = 400kHz$

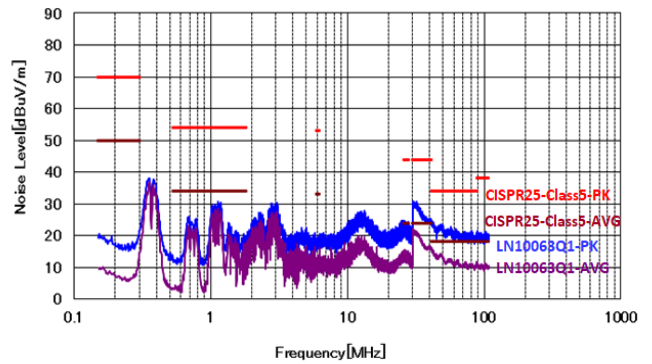

**Figure 32. Conducted EMI Performance (CISPR25 Conductive Emission Test with Class 5 Limits, N(-))**  
LN10163Q1,  $V_{IN} = 12V$ ,  $I_{OUT} = 3A$ ,  $F_S = 400kHz$

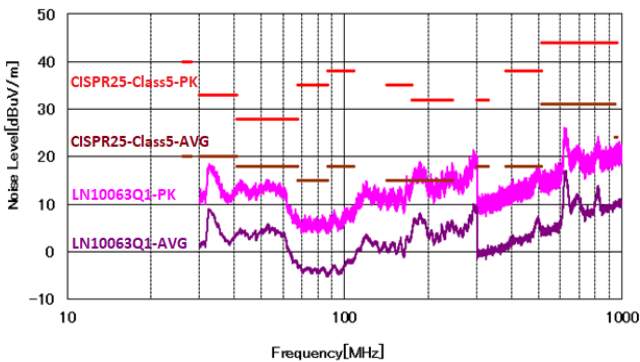

**Figure 33. Radiated EMI Performance (CISPR25 Radiated Emission Test with Class 5 Limits, Vertical Polarization)**  
LN10163Q1,  $V_{IN} = 12V$ ,  $I_{OUT} = 3A$ ,  $F_S = 400kHz$

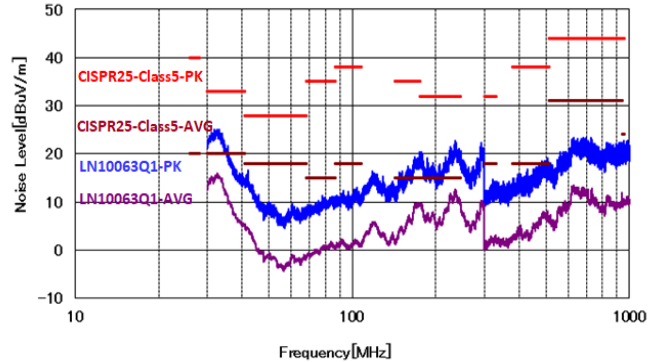

**Figure 34. Radiated EMI Performance (CISPR25 Radiated Emission Test with Class 5 Limits, Horizontal Polarization)**  
LN10163Q1,  $V_{IN} = 12V$ ,  $I_{OUT} = 3A$ ,  $F_S = 400kHz$

## 8 FUNCTIONAL DESCRIPTION

### 8.1 Overview

The LN10X62/3Q1 is a high efficiency, compact, synchronous step-down DC-DC converter employing a constant frequency, peak current mode control architecture with internal compensation. It operates from an input voltage from 3.5V to 60V, provides an adjustable output voltage from 1V to  $V_{IN}$ . LN10X62Q1 can deliver up to 2.5A of output current, while LN10063Q1 can deliver up to 3.0A. The switching frequency range is from 200kHz to 2.5MHz.

The LN10X62/3Q1 features up to 2.5MHz adjustable high frequency operation through either an external resistor or synchronization with an external clock. With a low minimum on-time, it enables a very compact solution with small inductor and capacitor size and offers constant-frequency operation with very high step-down ratio. In addition, the LN10X62/3Q1 achieves the lowest possible dropout voltage with 100% maximum duty cycle operation. During light load operation, LN10X62/3Q1 operates at DCM and PFM to maximize efficiency. The LN10X62/3Q1 employs a bypass LDO which allows to generate  $V_{CC}$  from a lower voltage supply other than  $V_{IN}$  to further improve system efficiency.

The LN10X62/3Q1 also offers a plural of features include programmable output voltage, adjustable soft start and tracking capability, power good flag, and a wide array of protection features such as cycle-by-cycle peak current limit, output short-circuit protection with hiccup mode, over temperature shutdown and recovery, and adjustable system UVLO.

### 8.2 Funtional Diagram

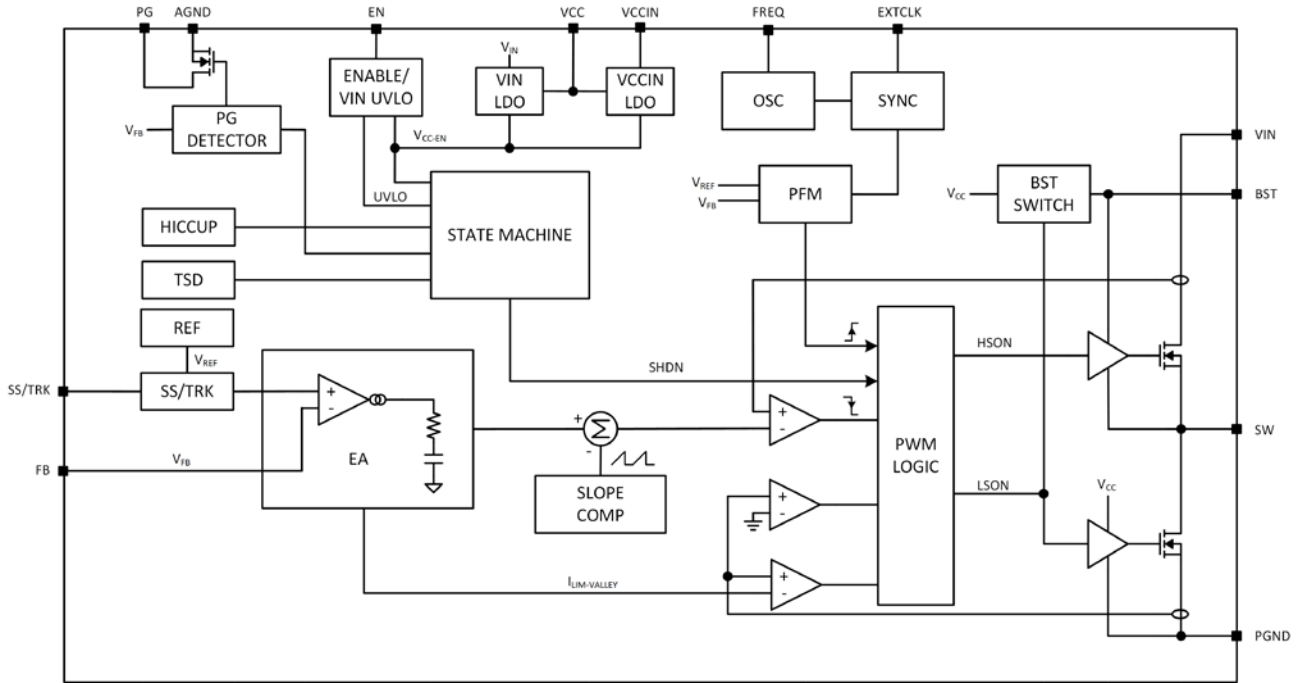

### 8.3 Application Diagram with Full Features

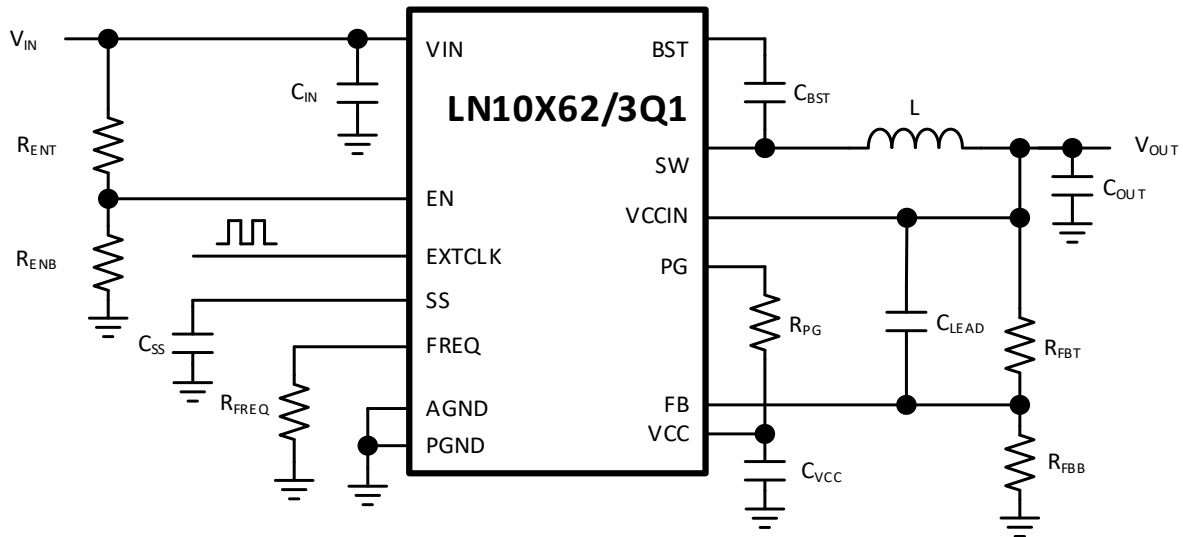

## 8.4 Funtional Description

### 8.4.1 Voltage Regulation Loop and FB pin

The LN10X62/3Q1 employs a peak current mode Control to regulate the output voltage. For highly efficient operation cross the whole load range. The LN10X62/3Q1 utilizes Discontinuous Conduction Mode (DCM) and Pulse Frequency Modulation (PFM) at light load.

To adjust the output voltage, connect a voltage divider between  $V_{OUT}$  and GND, and connect the center of the divider to FB pin. The steady state  $V_{FB}$  is typically 1V. The output voltage can be derived from:

$$V_{OUT} = \left(1 + \frac{R_{FBT}}{R_{FBB}}\right) \times V_{FB}$$

Based on the output voltage requirements, the above equation can be re-written as:

$$R_{FBB} = \frac{V_{FB}}{V_{OUT} - V_{FB}} \times R_{FBT}$$

In general,  $R_{FBT} < 1M\Omega$  is recommended. The tolerance of the divider resistance should be less than 1%, and the temperature coefficients should be less than 100ppm.

The LN10X62/3Q1 uses an internal compensation scheme to stabilize the control loop, an external RC lead compensation network can be connected between  $V_{OUT}$  and FB to improve transient response. An external lead compensation can be achieved by adding a resistor in parallel with the upper leg resistor of the voltage divider between  $V_{OUT}$  and FB pins.

The zero frequency of the external lead compensator is at:

$$f_z = \frac{1}{2\pi \times R_{FBT} \times C_{LEAD}}$$

While the pole frequency of the external lead compensator is at:

$$f_p = \frac{1}{2\pi \times (R_{FBT} // R_{FBB}) \times C_{LEAD}}$$

The added external lead compensator can increase the loop gain by  $\left(1 + \frac{R_{FBT}}{R_{FBB}}\right)$ .

#### 8.4.2 Internal V<sub>CC</sub> Regulators, V<sub>CC</sub> and V<sub>CCIN</sub> Pins

V<sub>CC</sub> powers the internal control circuits and the gate drivers for the internal power MOSFETs. There are two LDO regulators with inputs from V<sub>IN</sub> and V<sub>CCIN</sub> respectively. During powerup, V<sub>CC</sub> is powered by the V<sub>IN</sub> LDO regulator and is regulated to 5V. When V<sub>CCIN</sub> rises above the switchover threshold, V<sub>CC</sub> automatically switches to the output of the output of V<sub>CCIN</sub> LDO regulator. It is recommended for the applications with V<sub>OUT</sub> between 3.3V and 20V to connect V<sub>CCIN</sub> to V<sub>OUT</sub> to utilize the higher conversion efficiency of the switching regulator. When V<sub>CCIN</sub> LDO regulator is not used, connect V<sub>CCIN</sub> to PGND V<sub>CC</sub> must be decoupled to PGND with a 1 - 4.7μF ceramic capacitor.

#### 8.4.3 V<sub>IN</sub> UVLO and EN Pin

EN pin turns on and off the switching regulator and internal V<sub>CC</sub> LDO. When the voltage on EN pin is below EN<sub>VCC-OFF</sub>, it shuts down V<sub>CC</sub> LDO and the chip goes into shutdown mode. When the voltage on EN pin is above EN<sub>VCC-ON</sub>, it turns on V<sub>CC</sub> LDO.

An accurate threshold is placed at typical 2.1V, when EN rises above this threshold, it turns on the switching regulator. This accurate threshold serves to provide an accurate system V<sub>IN</sub> UVLO level. In the application, an enable divider can be added between V<sub>IN</sub> and GND. The switching regulator can thus be turned on and off at programmable precise input voltages.

The switching regulator Enable to Disable hysteresis is at typical -200mV. The VIN UVLO threshold can be determined by:

$$V_{IN-RISING} = \left(1 + \frac{R_{ENT}}{R_{ENB}}\right) \times EN_{VOUT-ON}$$

#### 8.4.4 Switching Frequency and FREQ Pin

The switching frequency of LN10X62/3Q1 is programmable between 200kHz to 2.5MHz by an external resistor connected between FREQ pin and AGND. R<sub>FREQ</sub> is calculated from:

$$R_{FREQ}(k\Omega) = \frac{134311}{F_S(kHz)^{1.062}} - 23$$

$R_{FREQ}$  vs. Switching frequency is plotted as:

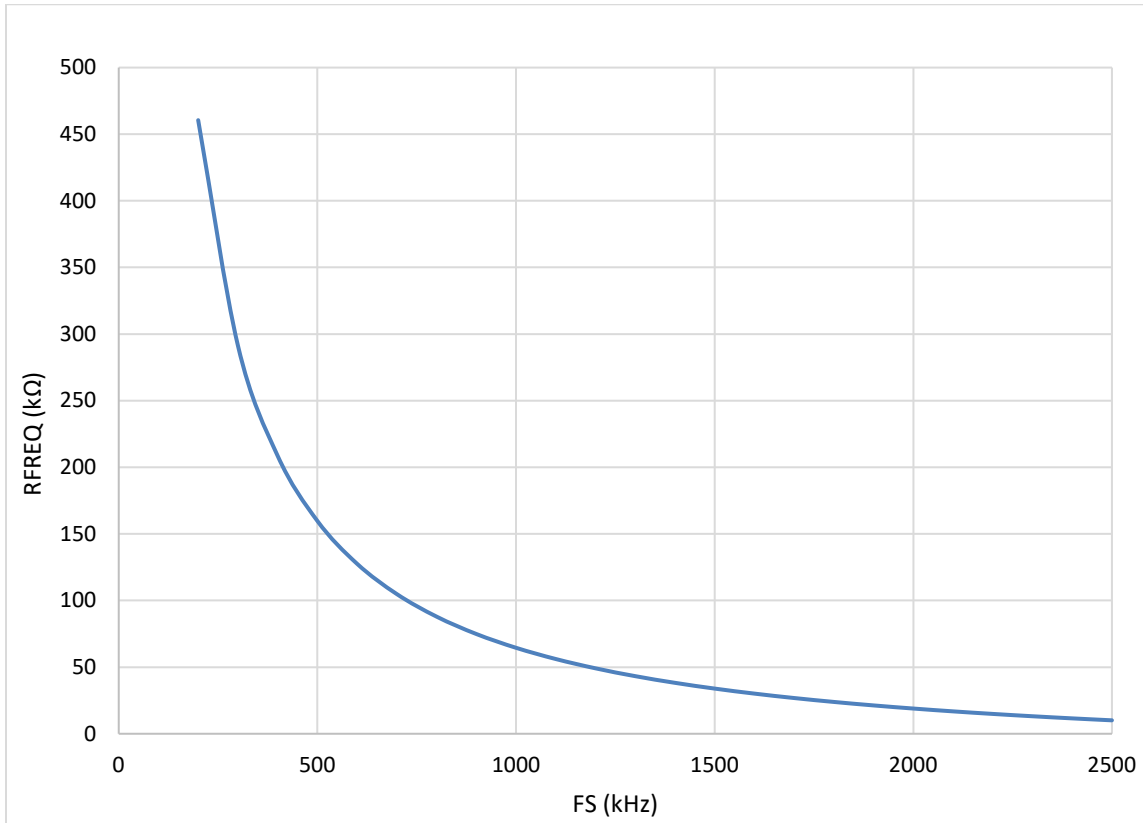

The following table lists some typical switching frequency and corresponding  $R_{FREQ}$ .

$R_{FREQ}$ (kΩ)	$F_s$ (kHz)
10	2500
18.7	2000
34	1500
64.9	1000
158	500
210	400
470	200

#### 8.4.5 Synchronization to External Clock and EXTCLK Pin

LN10X62/3Q1 is capable of being synchronized to an external clock between 200kHz to 2.5MHz. Connect the external clock signal to EXTCLK pin. When this function is not used, connect EXTCLK pin to AGND through a 10kΩ resistor. Connect a  $R_{FREQ}$  that provides similar switching frequency can minimize the dynamics during the turn on and off of the external sync clock.



#### 8.4.6 Power Good and PG Pin

The PG pin is connected to the open drain of an internal N-MOSFET. Externally, the PG pin needs to be pulled up to a voltage source by a resistor. Power Good goes high when  $V_{EN}$  is high and the feedback voltage  $V_{FB}$  is within the power good window defined by PG rising threshold and PG falling threshold. There is a power good rising delay  $T_{PG-RISING}$  of 320 $\mu$ s in response to  $V_{FB}$  voltage going into the power good window and a power good falling delay  $T_{PG-FALLING}$  of 320 $\mu$ s in response to  $V_{FB}$  voltage going outside of the window. PG pin immediately goes low when  $V_{EN}$  goes low.

#### 8.4.7 Soft Start, Tracking, and SS/TRK Pin

LN10X62/3Q1 has an internal soft-start ramp of about 5.1ms. To use the internal soft-start ramp, leave this pin open. The device also supports externally programmable soft-start ramp and tracking mode through the SS/TRK pin. The voltage on this pin sets the limit for internal reference voltage for regulation. Connect a capacitor between this pin and AGND sets the ramp time for output voltage. An internal 2.6 $\mu$ A current charges the external capacitor, the internal reference voltage follows the voltage on this pin if the external ramp voltage is less than the internal ramp voltage. The soft start time can be calculated:

$$t_{SS} = C_{SS} \times \frac{V_{REF}}{I_{SS-CHARGE}}$$

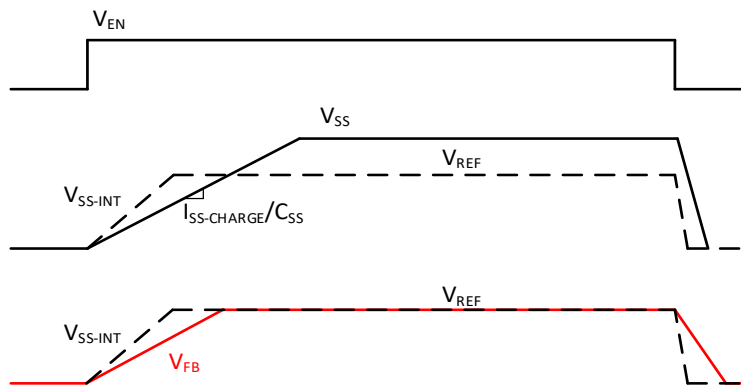

Externally programmable soft-start waveforms

This pin can also be driven to an external voltage ramp. When the external voltage is less than the internal ramp voltage, the output voltage tracks the external voltage ramp. When the tracking voltage is above 1V, internal reference is clamped to be 1V.

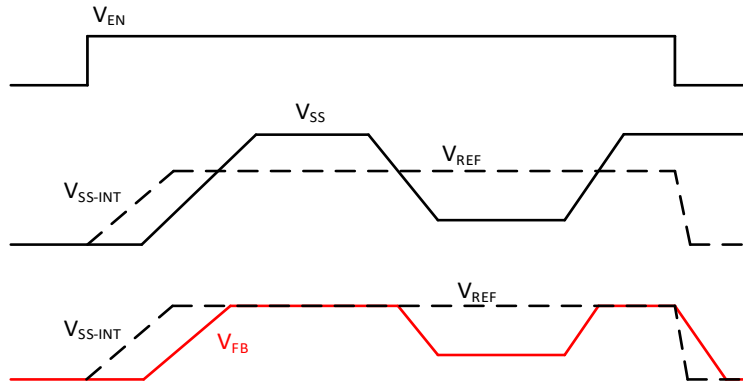

Soft start waveforms for tracking external voltage

LN10X62/3Q1 supports start up into pre-biased output voltage. When the soft start ramp voltage is lower than  $V_{FB}$  voltage, the control loop does not produce PWM pulses; only when the soft start ramp voltage is close to or rises above  $V_{FB}$  voltage, the control algorithm regulates  $V_{FB}$  to follow the soft start ramp.

## 8.4.8 Over-Current Protection

### 8.4.8.1 Peak Current Protection

Peak current protection is a cycle-by-cycle protection inherited from the peak current mode control. The peak current command is clamped to the Peak Current Limit Threshold.

### 8.4.8.2 Valley Current Protection

During low side conduction, the low side power MOSFET current is sensed and compared to valley current threshold. When low side current is higher than the valley current threshold, high side power MOSFET is not allowed to turn on for the next cycle.

### 8.4.8.3 Hiccup Mode

When low side current is higher than the valley current threshold for 32 cycles, it shuts down the switching regulator. The switching regulator automatically turns back on after 5ms if EN is high. During shutdown period, the soft start ramp capacitor is discharged by an internal FET; when the switching regulator turns back on, the regulator goes through the soft start process.

#### 8.4.9 Thermal Shutdown and Auto-Recovery

When the junction temperature exceeds 160°C, LN10X62/3Q1 shuts down the switching regulator to reduce thermal dissipation. It automatically restarts the switching regulator after junction temperature drops back below 150 °C. The  $V_{CC}$  LDO regulators remain operational during over-temperature event.

#### 8.4.10 Bootstrap Voltage, BST, and SW Pin

The internal gate driver for the high side Power MOSFET uses a bootstrapped supply from an external capacitor  $C_{BST}$ .  $C_{BST}$  connect between BST pin and SW. The voltage on  $C_{BST}$  is charged from  $V_{CC}$  through an internal switch when the low side power MOSFET conducts.

#### 8.4.11 Low Drop-Out

When input voltage is close to the output target voltage, LN10X62/3Q1 enters Low Drop-Out mode. The high-side MOSFET can be turned on for more than a switching period to maintain the output voltage regulation. When the input voltage is lower than the target voltage, the high-side power MOSFET is turned on for maximum allowable on time:  $t_{REFRESH-PE}$ . The low-side power MOSFET turns on briefly for  $T_{OFF-MIN}$  to refresh the charge on  $C_{BST}$ .

## 9 APPLICATION INFORMATON

### 9.1 Typical Applications

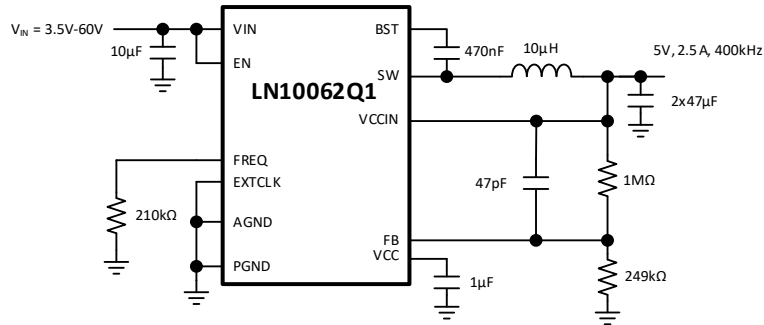

Figure 35. LN10062Q1, 400kHz, 5V, 2.5A Typical Application Diagram

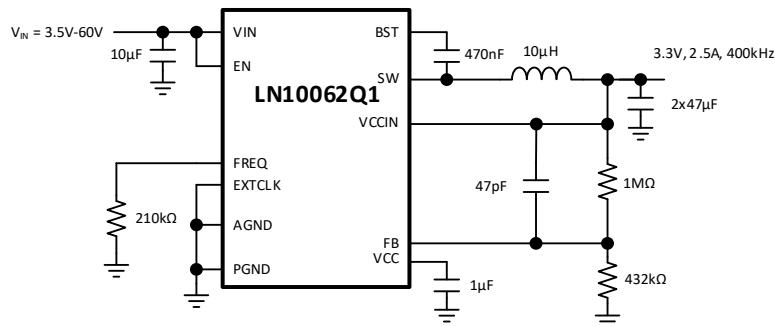

Figure 36. LN10062Q1, 400kHz, 3.3V, 2.5A Typical Application Diagram

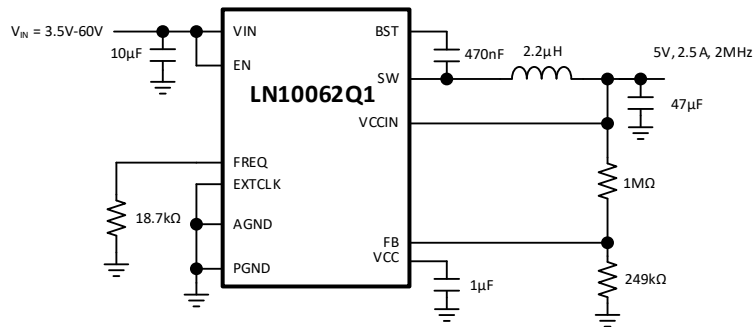

Figure 37. LN10062Q1, 2MHz, 5V, 2.5A Typical Application Diagram

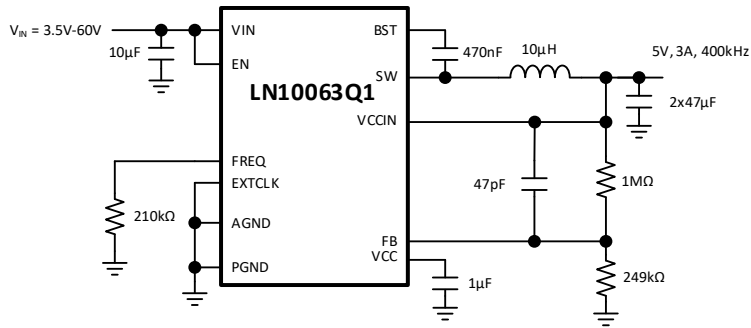

Figure 38. LN10063Q1, 400kHz, 5V, 3A Typical Application Diagram

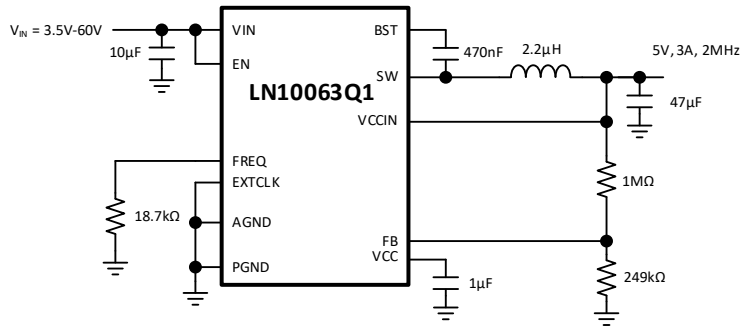

Figure 39. LN10063Q1, 2MHz, 5V, 3A Typical Application Diagram

## 9.2 Typical External Components

R <sub>FREQ</sub> (kΩ)	V <sub>OUT</sub> (V)	V <sub>IN</sub> Range (V)	C <sub>OUT</sub> (μF)	L (μH)	R <sub>FBT</sub> (kΩ)	R <sub>FBB</sub> (kΩ)	C <sub>LEAD</sub> (pF) <sup>(3)</sup>
<b>F<sub>s</sub> = 2.0 MHz</b>							
18.7 kΩ	3.3	3.5 – 13 <sup>(1)</sup>	47	2.2	1000	432	47
	5	5 – 20 <sup>(1)</sup>	47	2.2	1000	249	47
	12	12 – 60 <sup>(2)</sup>	22	8.2	1000	90.9	NA
	24	24 – 60 <sup>(2)</sup>	22	15	1000	43.2	NA
<b>F<sub>s</sub> = 1 MHz</b>							
64.9 kΩ	1	3.5 – 9 <sup>(1)</sup>	100	2.2	Short	Open	Short
	3.3	3.5 – 29 <sup>(1)</sup>	100	6.8	1000	432	47
	5	5 – 60	100	8.2	1000	249	47
	12	12 – 60	22	18	1000	90.9	NA
	24	24 – 60	22	27	1000	43.2	NA
<b>F<sub>s</sub> = 400 kHz</b>							
210kΩ	1	3.5 – 21 <sup>(1)</sup>	200	4.7	Short	Open	Short
	3.3	3.5 – 60	100	10	1000	432	47
	5	5 – 60	100	10	1000	249	47
	12	12 – 60	22	22	1000	90.9	47
	24	24 – 60	22	47	1000	43.2	NA

- 1) The maximum output voltage is limited by T<sub>ON-MIN</sub>.
- 2) At high switching frequency, the maximum output current may not be guaranteed due to over temperature protection.
- 3) With large ESR capacitor, the lead compensation may not be needed.

## 10 LAYOUT

The performance of any switching converter depends as much upon the layout of the PCB as the component selection. The LN10X62/3Q1 is designed to meet the optimization requirements of PCB layout in the pin assignment. For example, VIN and PGND pins are adjacent to each other, which is convenient for placing VIN bypass capacitors.

### 10.1 Layout Guidelines

Radiated EMI is generated by the high  $di/dt$  components in pulsing currents in switching converters. The larger area covered by the path of a pulsing current; the more electromagnetic emission is generated. As shown in the figure below, this part of the current flows from the VIN side of the input capacitors to high side switch, to the low side switch, and then returns to the ground of the input capacitors.

The key to minimize radiated EMI is to minimize the area of this pulsing current path, thus, placing high frequency ceramic bypass capacitor(s) as close as possible to the VIN and PGND pins is necessary.

In addition, high  $dv/dt$  occurs on SW node during switching, so the trace between SW pin and inductor should be as short as possible, and just wide enough to carry the load current without excessive heating. Short and thick traces are highly recommended to minimize parasitic resistance. Besides, sensitive signal lines should be kept away from SW traces.

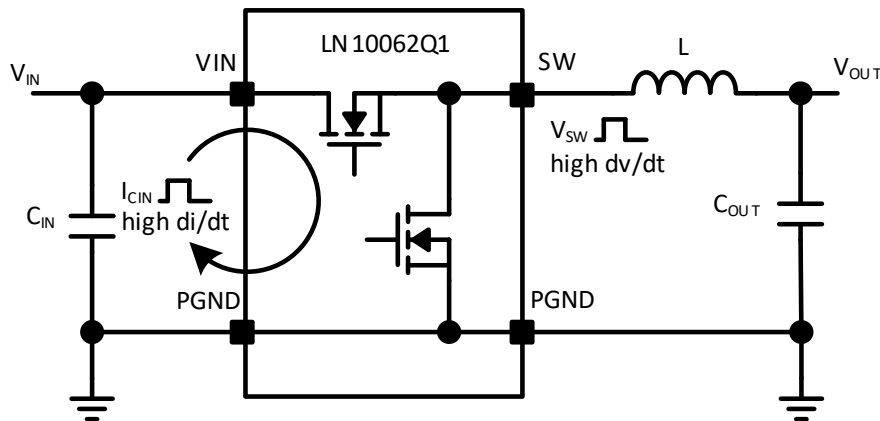

The following guidelines will help users design a PCB with the best power conversion performance, thermal performance, and minimized generation of unwanted EMI.

1. Place high frequency ceramic bypass  $C_{IN}$  as close as possible to the LN10X62/3Q1 VIN and PGND pins; a ceramic capacitor in small package (such as 0603) is still needed even if multiple input capacitors are implemented;
2. The high-current loop consisting of VIN, SW, VOUT and GND should be as compact as possible;
3. The bypass capacitors of VCCIN and VCC should be arranged close to the pins, and return to the PGND pin with the shortest connection;

4. It is recommended to use a four-layer board with a top and bottom layer of 2oz copper, and a complete ground plane on middle layer. Use a minimum 3 by 4 arrays of 10 mil thermal vias to connect the thermal pad of LN10X62/3Q1 to the system ground plane for heat sinking;
5. The SW and BST nodes contains a lot of high-frequency noise, so the connection of the pins should be as short as possible, meanwhile, there should be sufficient width to conduct the current;
6. Sensitive analog signals, such as FB, SS and FREQ, need to be far away from the noisy nodes, ground plane can be used as a shielding layer while routing these sensitive signals;
7. The feedback resistance of the FB connection must be located as close to the pin as possible, If  $V_{OUT}$  accuracy at the load is important, make sure  $V_{OUT}$  sense is made at the load;
8. For the peripheral components connected to FB, FREQ, SS and EN pins, a single point ground connection to the plane is recommended.

## 10.2 Layout Example

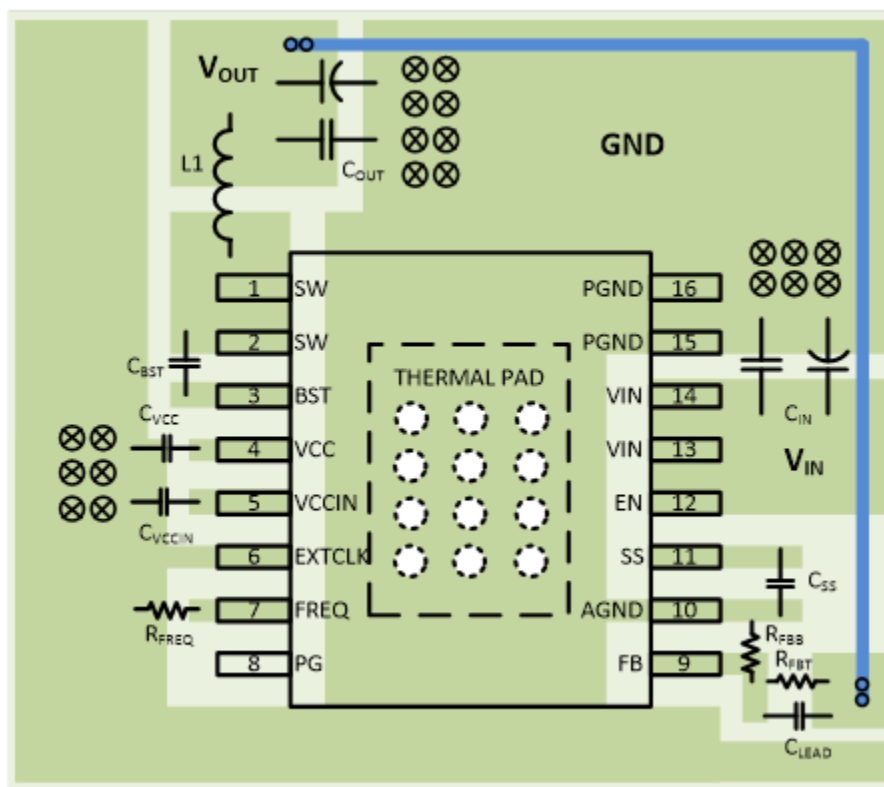

LN10X62/3Q1 Layout



11 PACKAGE INFORMATION

11.1 Package Outline

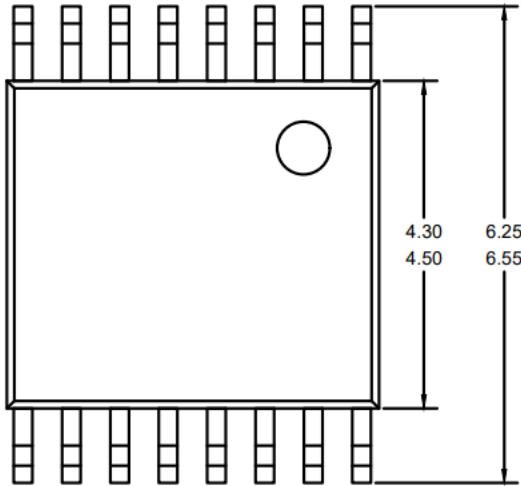

TOP VIEW

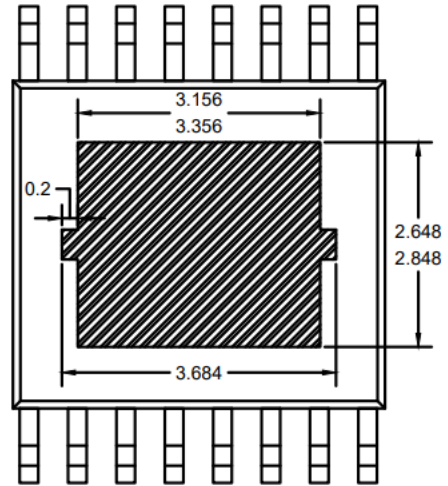

BOTTOM VIEW

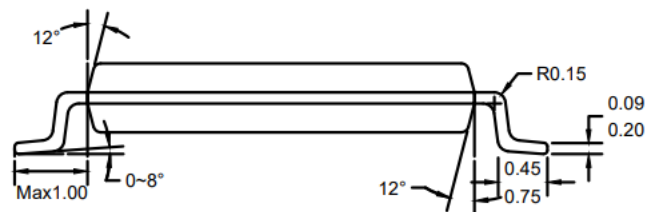
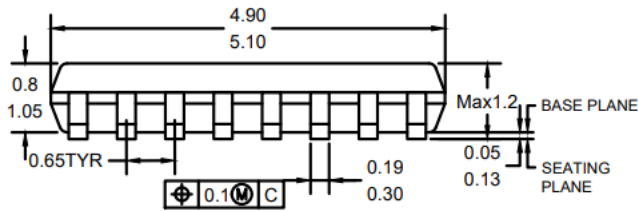

Notes:

1. Both package length and width do not include mold flash.
2. Controlling dimension: mm

**11.2 Footprint Example**

**LAND PATTERN EXAMPLE**  
**EXPOSED METAL SHOWN**

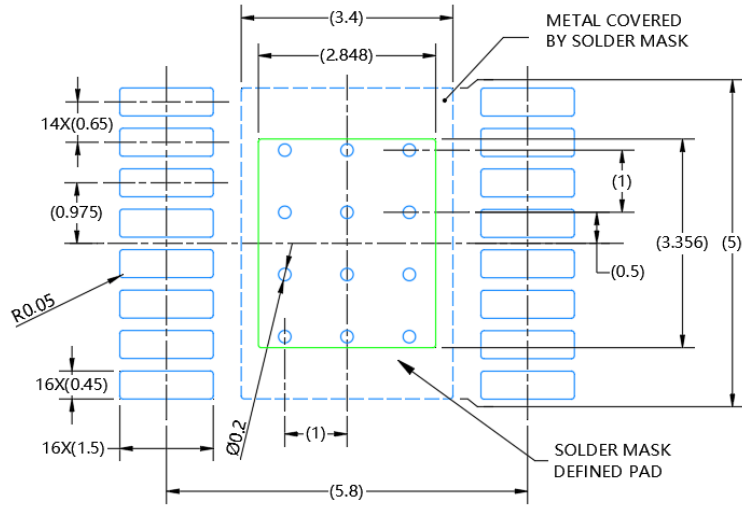

**SOLDER PASTE EXAMPLE**  
**BASED ON 0.125 mm THICK STENCIL**

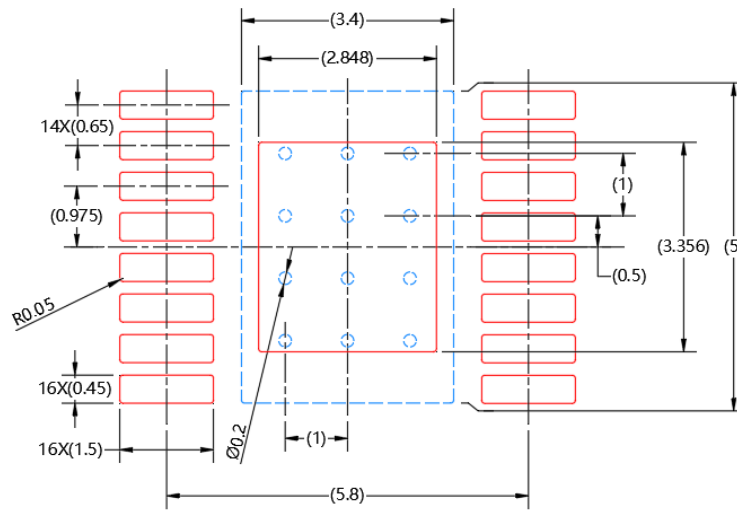

### **IMPORTANT NOTICE AND DISCLAIMERS**

The technical materials, reliability data, product specifications, and related product evaluation boards provided by LEN Technology Ltd. are on an "as is" basis. LEN Technology Ltd. is not responsible for any errors that may occur in these resources. LEN Technology Ltd. disclaims all expressed and implied warranties, including any implied warranties that the intellectual property rights of third parties will not be infringed.

These resources from LEN Technology Ltd. are provided only to those who have experience in developing electronic products. You will be solely responsible for selecting appropriate products from LEN Technology Ltd., and for verifying and testing your design to meet the standards of your application, as well as for any other safety and security requirements.

The resources provided by LEN Technology Ltd. are subject to change without notice. LEN Technology Ltd. Only grants you the rights for developing applications with the products of LEN Technology Ltd. described in these resources. Reproduction and display of these resources is prohibited. LEN Technology Ltd. does not grant any other intellectual property rights owned by LEN Technology Ltd. or any third-party licensed intellectual property. LEN Technology Ltd. does not assume any loss, cost and liabilities for the use of these resources.

### **ENVIRONMENTAL DECLARATION**

This product complies with the requirements of RoHS and REACH. In accordance with relevant Chinese regulations and standards, it does not contain toxic or harmful substances or elements.