

## 5 -VOLT FIXED VOLTAGE REGULATORS

### DESCRIPTION

The SG109/SG309 is a completely self-contained 5V regulator. Designed to provide local regulation at currents up to 1A for digital logic cards, this device is available in the hermetic TO-3, TO-66, TO-39 and hermetic and plastic TO-220.

A major feature of the SG109's design is its built-in protective features which make it essentially blowout proof. These consist of both current limiting to control the peak currents and thermal shutdown to protect against excessive power dissipation. With the only added component being a possible need for an input bypass capacitor, this regulator becomes extremely easy to apply. Utilizing an improved Bandgap reference design, problems have been eliminated that are normally associated with the zener diode references, such as drift in output voltage and large changes in the line and load regulation.

### FEATURES

- Fully compatible with TTL and DTL
- Output current in excess of 1A
- Internal thermal overload protection
- No additional external components
- Bandgap reference voltage
- Foldback current limiting

### HIGH RELIABILITY FEATURES-SG109

- ◆ Available to MIL-STD-883
- ◆ MIL - M38510 / 10701BXA - JAN109T
- ◆ Radiation data available
- ◆ LMI level "S" processing available

### SCHEMATIC

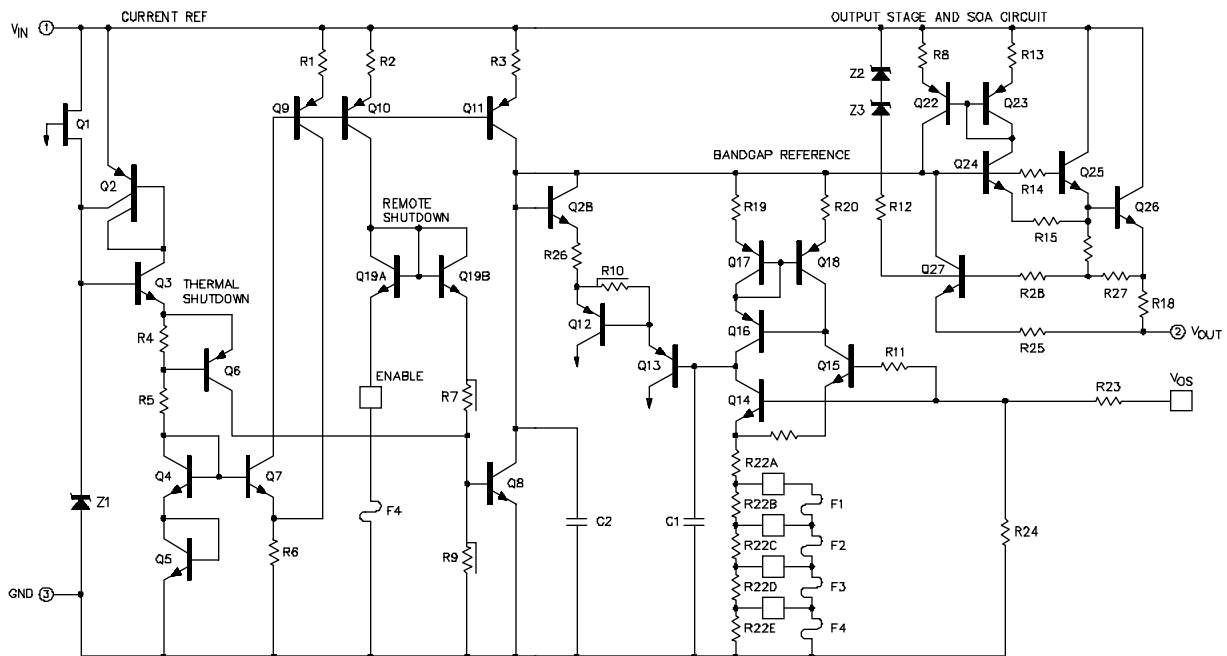

## ABSOLUTE MAXIMUM RATINGS (Note 1)

Input Voltage ..... 35V  
 Power Dissipation ..... Internally Limited  
 Storage Temperature Range ..... -65°C to 150°C

Operating Junction Temperature  
 Hermetic (K, R, T, IG-Packages) ..... 150°C  
 Lead Temperature (Soldering, 10 Seconds) ..... 300°C

Note 1. Exceeding these ratings could cause damage to the device.

## THERMAL DATA

K Package:

Thermal Resistance-Junction to Case,  $\theta_{JC}$  ..... 3.0°C/W  
 Thermal Resistance-Junction to Ambient,  $\theta_{JA}$  ..... 35°C/W

R Package:

Thermal Resistance-Junction to Case,  $\theta_{JC}$  ..... 5.0°C/W  
 Thermal Resistance-Junction to Ambient,  $\theta_{JA}$  ..... 40°C/W

IG Package:

Thermal Resistance-Junction to Case,  $\theta_{JC}$  ..... 3.5°C/W  
 Thermal Resistance-Junction to Ambient,  $\theta_{JA}$  ..... 42°C/W

T Package:

Thermal Resistance-Junction to Case,  $\theta_{JC}$  ..... 15°C/W  
 Thermal Resistance-Junction to Ambient,  $\theta_{JA}$  ..... 120°C/W

Note A. Junction Temperature Calculation:  $T_J = T_A + (P_D \times \theta_{JA})$ .

Note B. The above numbers for  $\theta_{JC}$  are maximums for the limiting thermal resistance of the package in a standard mounting configuration. The  $\theta_{JA}$  numbers are meant to be guidelines for the thermal performance of the device/pc-board system. All of the above assume no ambient airflow.

## RECOMMENDED OPERATING CONDITIONS (Note 2)

Input Voltage Range ..... 7.0V to 25V

Operating Junction Temperature Range  
 SG109 ..... -55°C to 150°C  
 SG309 ..... 0°C to 125°C

Note 2. Range over which the device is functional.

## ELECTRICAL CHARACTERISTICS

(Unless otherwise specified, these specifications apply over the operating ambient temperatures for SG109 with  $-55^\circ\text{C} \leq T_A \leq 150^\circ\text{C}$ , SG309 with  $0^\circ\text{C} \leq T_A \leq 125^\circ\text{C}$ , and for  $V_{IN} = 10\text{V}$ ,  $I_{OUT} = 500\text{mA}$  (K, R, and IG-Power Packages-) and  $I_{OUT} = 100\text{mA}$  (T-package). Low duty cycle pulse testing techniques are used which maintains junction and case temperatures equal to the ambient temperature.)

Parameter	Test Conditions	SG109			SG309			Units
		Min.	Typ.	Max.	Min.	Typ.	Max.	
Output Voltage	$T_A = 25^\circ\text{C}$	4.7	5.05	5.3	4.8	5.05	5.2	V
Line Regulation	$V_{IN} = 7.1\text{V to } 25\text{V}$ , $T_A = 25^\circ\text{C}$		4.0	50		4.0	50	mV
Load Regulation	$T_A = 25^\circ\text{C}$							
	Power Pkgs: $I_{OUT} = 5\text{mA to } 1.5\text{A}$		15	100		15	100	mV
	T-package: $I_{OUT} = 5\text{mA to } 500\text{mA}$		15	50		15	50	mV
Total Output Voltage Tolerance	$V_{IN} = 7.4\text{V to } 25\text{V}$							
	Power Pkgs: $I_{OUT} = 5\text{mA to } 1.0\text{A}$ , $P \leq 20\text{W}$	4.6	5.0	5.4	4.75	5.00	5.25	V
	T-package: $I_{OUT} = 5\text{mA to } 200\text{mA}$ , $P \leq 20\text{W}$	4.6	5.0	5.4	4.75	5.00	5.25	V
Quiescent Current	$V_{IN} = 7.4\text{V to } 25\text{V}$			10			10	mA
Quiescent Current Change	With Line : $V_{IN} = 7.4\text{V to } 25\text{V}$			0.5			0.5	mA
	With Load: Power Pkgs: $I_{OUT} = 5\text{mA to } 1.0\text{A}$			0.8			0.8	mA
	T-package: $I_{OUT} = 5\text{mA to } 200\text{mA}$			0.8			0.8	mA
Output Noise Voltage	$f = 10\text{Hz to } 100\text{KHz}$ , $T_A = 25^\circ\text{C}$		40			40		$\mu\text{V}$
Long Term Stability			10			20		mV
Ripple Rejection	$T_A = 25^\circ\text{C}$	50			50			dB

## APPLICATION CIRCUITS

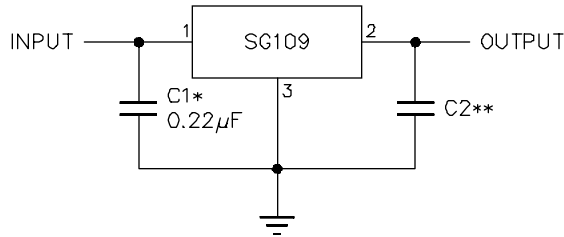

\* REQUIRED IF REGULATOR IS AN APPRECIABLE DISTANCE FROM POWER SUPPLY FILTER.  
 \*\* ALTHOUGH NO OUTPUT CAPACITOR IS NEEDED FOR STABILITY IT DOES IMPROVE TRANSIENT RESPONSE.

FIGURE 1 - FIXED 5V REGULATOR

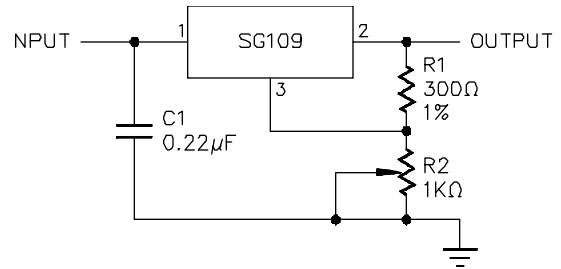

FIGURE 2 - ADJUSTABLE OUTPUT REGULATOR

## CONNECTION DIAGRAMS & ORDERING INFORMATION (See Notes Below)

Package	Part No.	Ambient Temperature Range	Connection Diagram
3-TERMINAL TO-3 METAL CAN K-PACKAGE	SG109K/883B SG109K SG309K	-55°C to 125°C -55°C to 125°C 0°C to 70°C	
3-TERMINAL TO-66 METAL CAN R-PACKAGE	SG109R/883B SG109R SG309R	-55°C to 125°C -55°C to 125°C 0°C to 70°C	
3-PIN HERMETIC TO-257 IG-PACKAGE (Isolated)	SG109IG/883B SG109IG	-55°C to 125°C -55°C to 125°C	
3-PIN TO-39 METAL CAN T-PACKAGE	SG109T/883B JAN109T SG109T SG309T	-55°C to 125°C -55°C to 125°C -55°C to 125°C 0°C to 70°C	

Note 1. Contact factory for JAN and DESC product availability. 3. Product is also available in leadless chip carrier (LCC) and hermetic flat pack (F).  
 2. All parts are viewed from the top. Contact factory for price and availability.

This datasheet has been downloaded from:

[www.DatasheetCatalog.com](http://www.DatasheetCatalog.com)

Datasheets for electronic components.